



THE POP-UP

QUICK START GUIDE



SUMMARY

STEP 1: HOW TO ASSEMBLE THE PHOTOBOOTH	3
1.1) How to install the photobooth	3
1.2.a) Install the DNP DS620 printer in the photo booth.	
1.2.b) Install the DNP QW410 printer in the photo booth	5
1.4) Turn on the photo booth.	
1.5.1) Load the consumables into the DNP DS620	10
1.5.2.a) Loading the ink ribbon	
1.5.1.b) Loading the paper	12
1.5.2) Load the consumables into the DNP QW410	15
1.5.2.a) Loading the ink ribbon	
1.5.1.b) Loading the paper	16
STEP 2: CONNECT AND UPDATE	19
2.1) First access to the photobooth and language change	19
2.2) Wi-Fi Connection	21
2.2) Windows updates	23
2.3) Software updates	26
STEP 3: CREATE AN ACCOUNT AND LINK IT TO THE PHOTOBOOTH	30
3.1) Create your account	30
3.2) Log in to your account	32
STEP 4: CREATE AND CONFIGURE AN EVENT	36
4.1) Create an event	36
4.2) Configure your event	39
4.2.1) Selection of your event type	39
4.2.2) Configuration of your "theme" event	41
STEP 5: DOWNLOAD AND LAUNCH THE EVENT ON THE PHOTOBOOTH	53
STEP 6: RECOVER THE MEDIA FROM YOUR EVENT	56

STEP 1: HOW TO ASSEMBLE THE PHOTOBOOTH

y1.1) How to install the photobooth

1. Open the carrying bag, grab your device by the handles, take it out of the bag (avoid lifting the pop-up by the arm), and place it on the ground or on a table.



2. Raise the arm of the pop-up bollard until you hear the "click."



3. Raise the tablet and tighten the handle.



4. Remove the power cable located at the back and plug it in.



1.2.a) Install the DNP DS620 printer in the photo booth.

1. To access the printer, open the printer access door by lifting the cover.



2. Slide the printer into the device and push it forward a bit so you can connect the power cable (which is already plugged into the outlet inside the photobooth) and the USB cable (which is already connected to the tablet).



Once the printer is plugged in and positioned at the back, secure it with straps to prevent any movement.



1.2.b) Install the DNP QW410 printer in the photo booth.

1. Open the contents of the envelopes inside the carrying bag. You should find the items listed below that correspond to the DNP QW410 adapter kit.



NOTE: For the next steps, you will need a nut driver in order to secure the kit.



2. Open the access door to the printer by lifting the cover.



3. Assemble the adaptation kit for the DNP QW410 and prepare your printer.

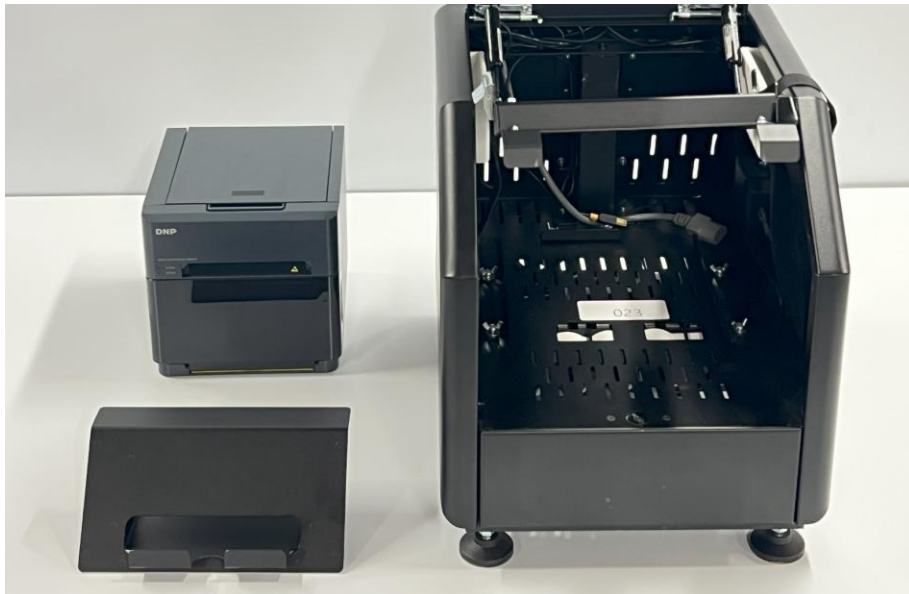

4. Unscrew the nuts on the inside of the printer access panel, remove the front cover, install the adapter kit, and then screw the nuts back in place.



5. Inside your printer's stand, loosen the nuts on the support bars and bring them closer together.

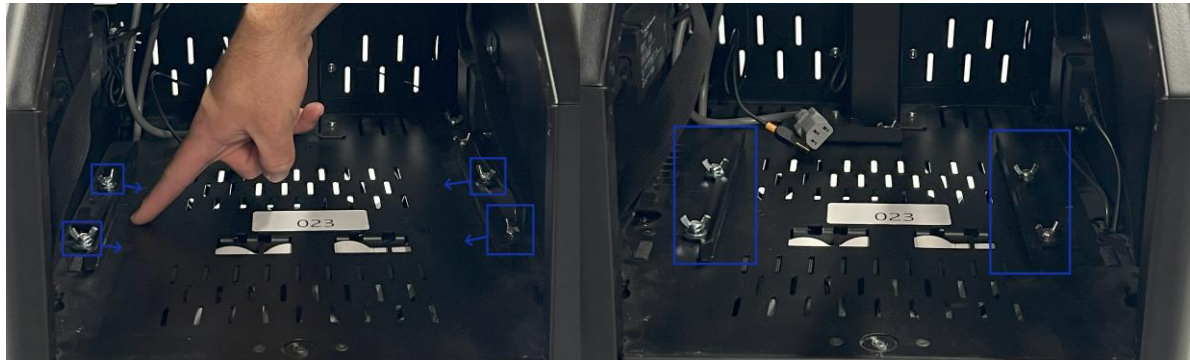

6. Insert your QW410 into the dock, connect the power and USB cables, and gently push it all the way in.



You can now turn on your photobooth (see point 1.4) and load its supplies (see point 1.5.b).

1.4) Turn on the photo booth

Once it's plugged in, turn on the device by pressing the ON/OFF button located on the back of the tablet, as shown below.



Press the dimmer briefly to turn on the lights at your station. You can adjust the brightness by holding it down for a bit longer.

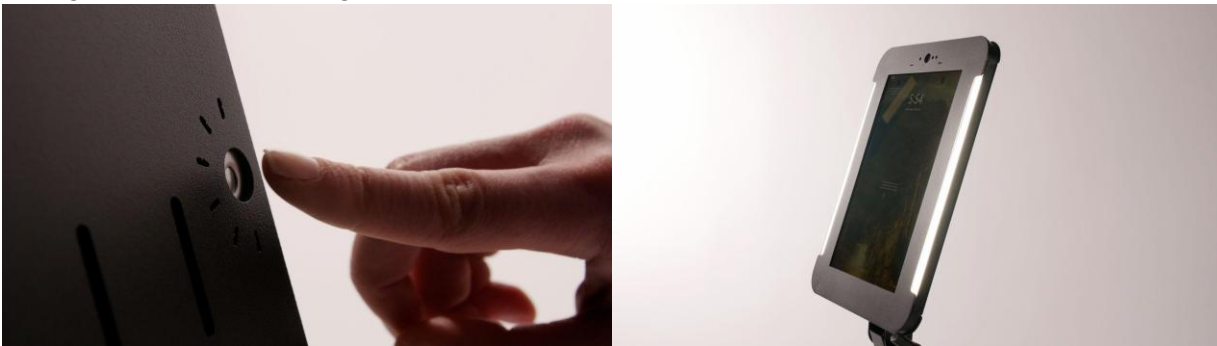

3. Press the ON/OFF button to turn on the printer.



DNP DS620

DNP QW410

1.5.1) Load the consumables into the DNP DS620

1. Open the printer by pulling on the opening lever.

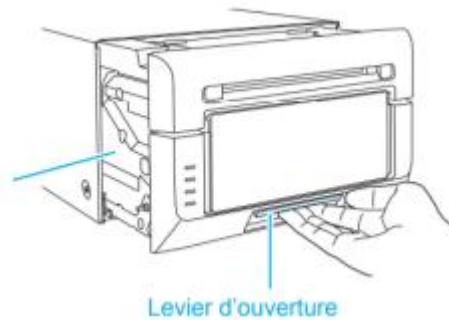

1.5.2.a) Loading the ink ribbon

1. Remove the ink ribbon holder from the printer.



2. Attach the new ribbon to the holder and gently turn the cylinders to tighten the ribbon. The ribbon with the yellow tip should be on the "handle" side of the mount.

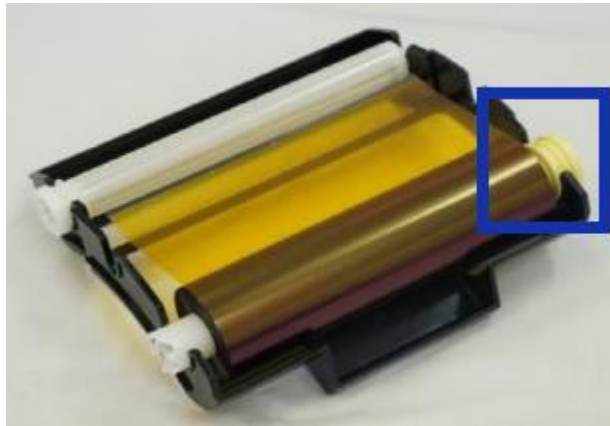

3. Put the holder with the new ink ribbon back in the printer drawer.



1.5.1.b) Loading the paper

1. Press the blue button located above to access the paper roll.

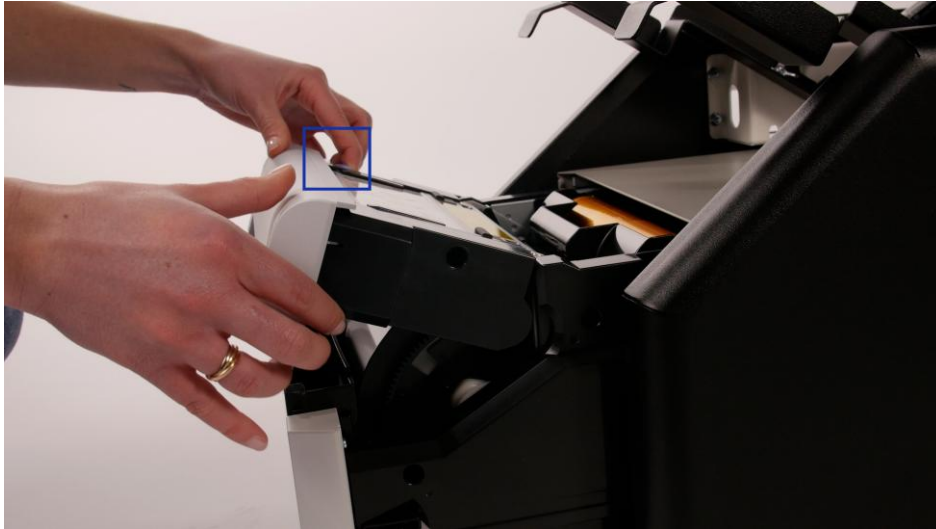

2. Remove the waste compartment.



3. Remove the two black cylinders.



4. Insert the two black cylinders on each side of the new roll of paper and place it in the printer. Make sure the start of the paper is facing you and pointing down, then roll it until you hear two beeps.



5. Put the waste compartment back.



6. Close the printer by pushing on the mechanism.



7. Lower the wedges and screw in the 2 wing screws.



The printer's lights will turn green, and it will start cutting 3 to 5 blank sheets to get ready for printing.



NOTE: We recommend always changing the paper and ribbon at the same time.

1.5.2) Load the consumables into the DNP QW410

1.5.2.a) Loading the ink ribbon

1. Pull the opening lever towards you to open the top door of the printer.

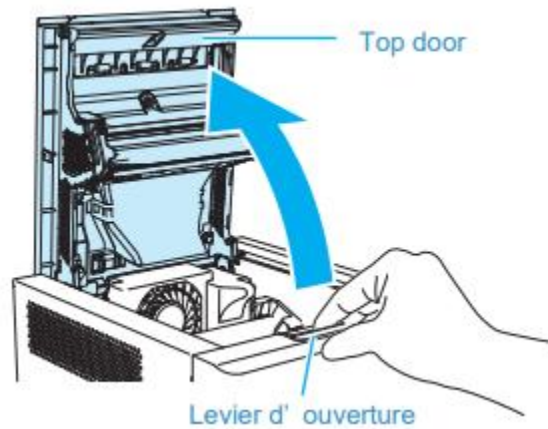

2. Install the ribbon.

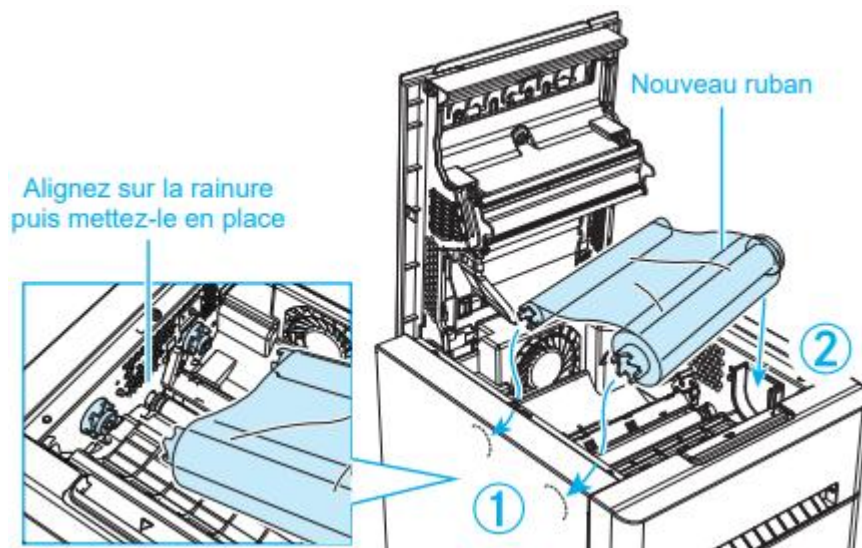

3. Close the top door of the printer.

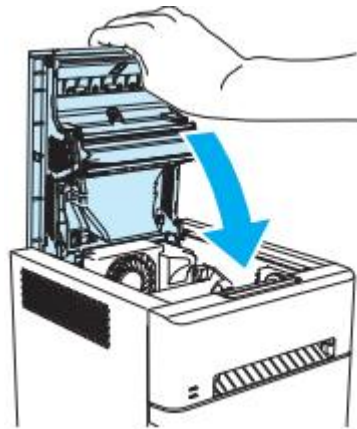

1.5.1.b) Loading the paper

1. Remove the printer's trash box.

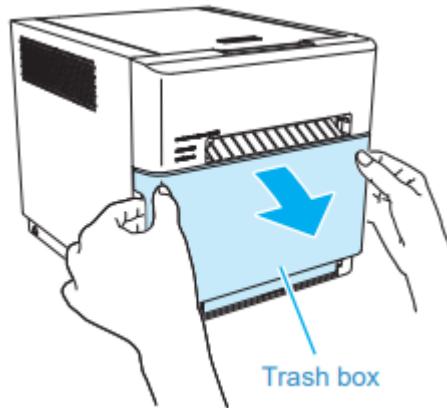

2. Retrieve the paper holder from the printer.

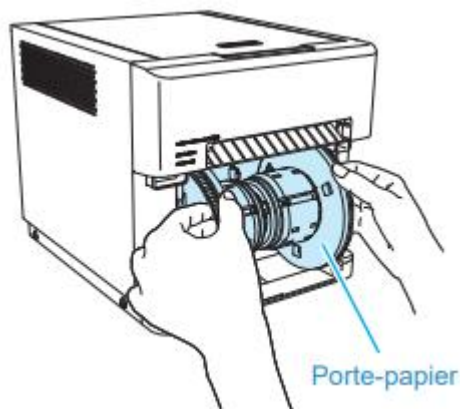

3. Install the new roll of paper, ensuring that there are no gaps.

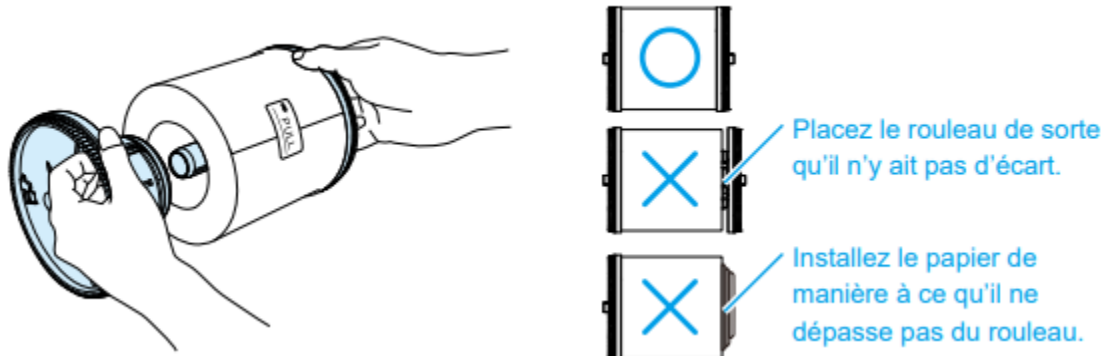

4. Insert the paper holder into the printer. Make sure to position the paper cover (→PULL) in the same direction as shown below.

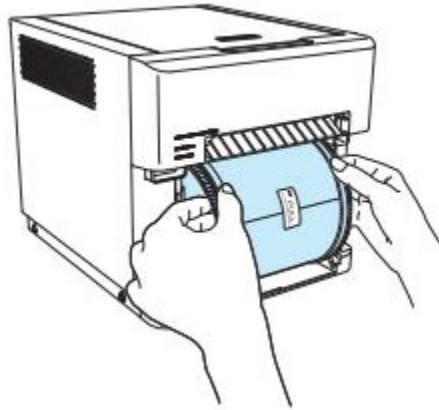

5. Remove the cover, place one hand on the paper, and turn the paper holder in the direction of the arrow to feed the edge of the paper until you hear a beep.

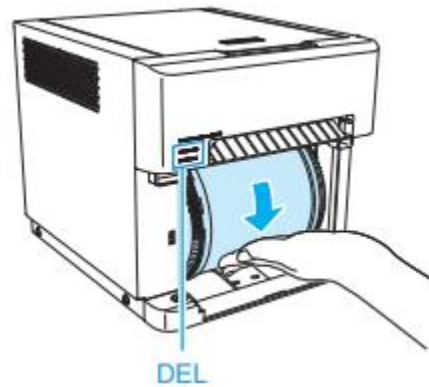

6. Put the printer's trash box back. Three blank sheets will come out.

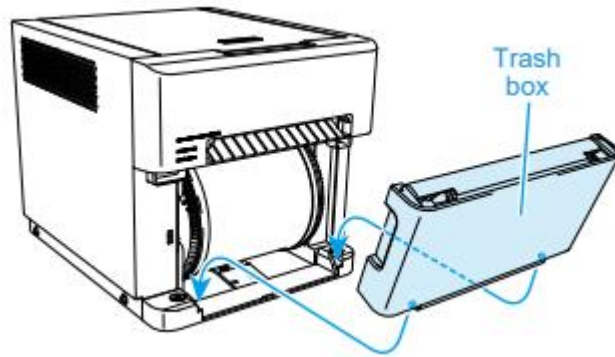

STEP 2: CONNECT AND UPDATE

2.1) First access to the photobooth and language change

When you receive the device and turn it on for the first time, the eventManager software by Sharingbox will automatically start up. It will be in English.

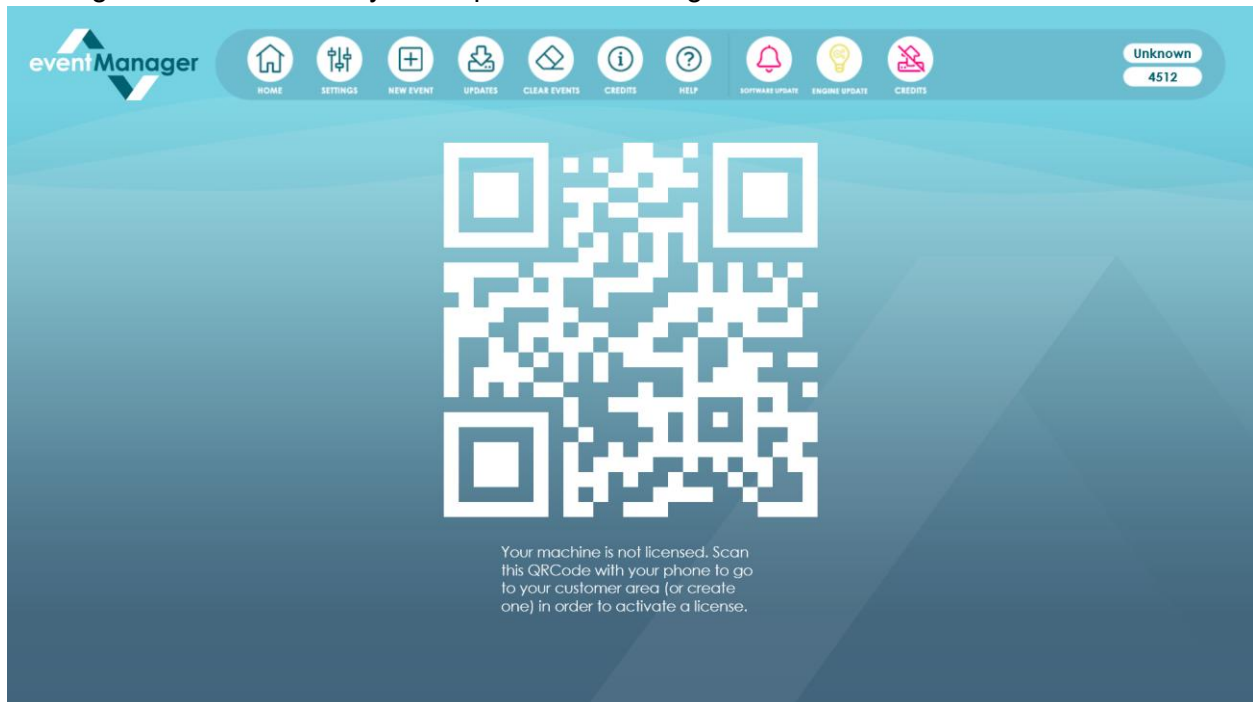

To change the language to French, go to "Settings," then click on the "Languages" button and select "Français."

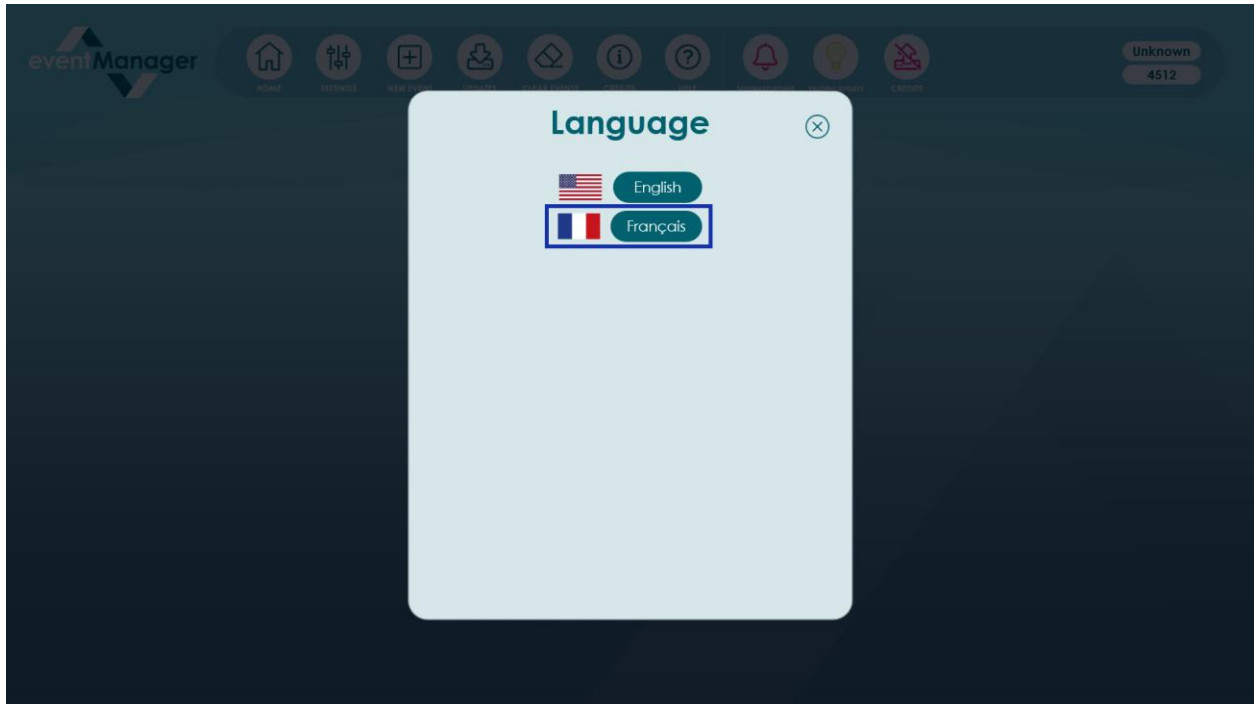
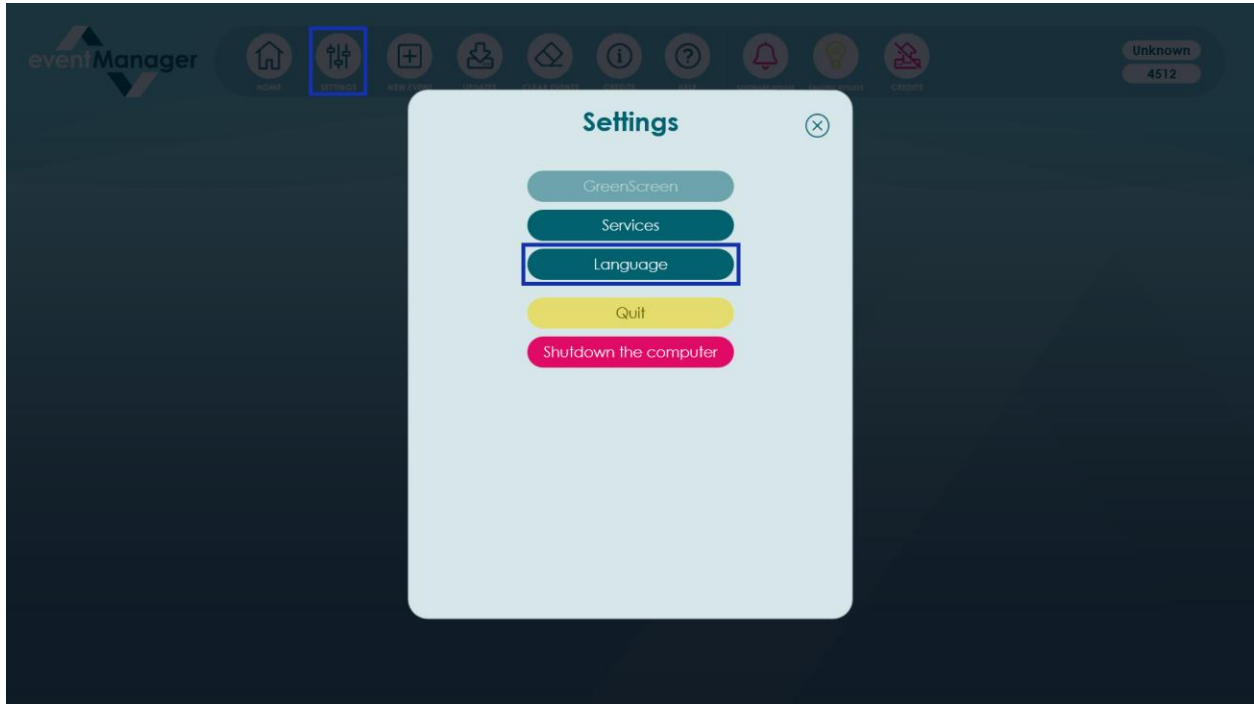

2.2) Wi-Fi Connection

Once the eventManager is *in* French

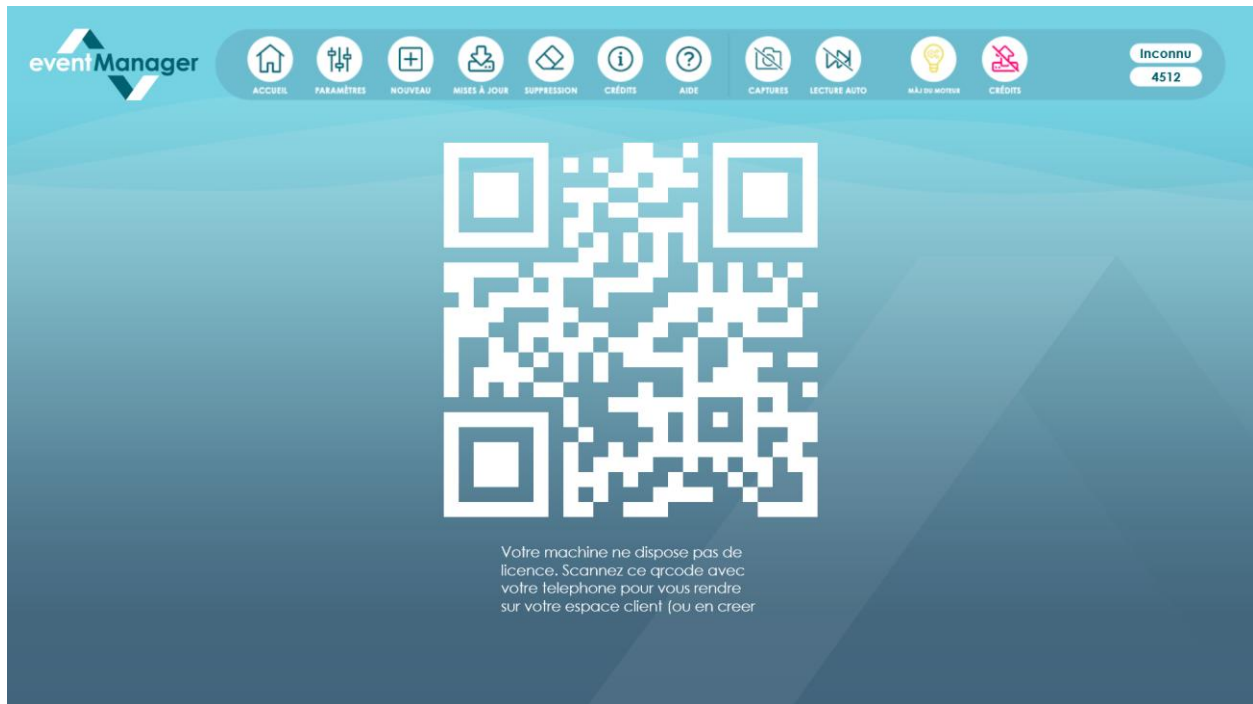

First, connect to your Wi-Fi on Windows. To do this, click on "Settings" in the top menu, and then select "Exit."

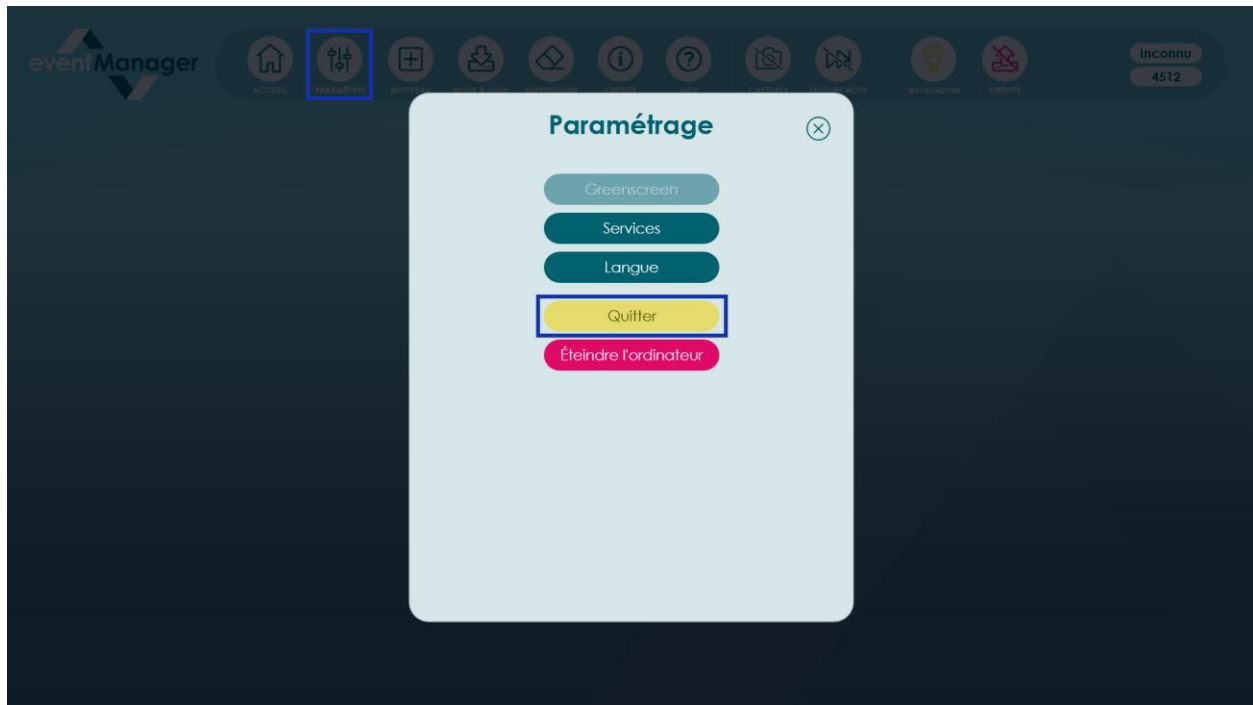

Once you're on your Windows desktop, click on the Wi-Fi icon in the bottom right corner of the screen, and then click the arrow next to the Wi-Fi icon.

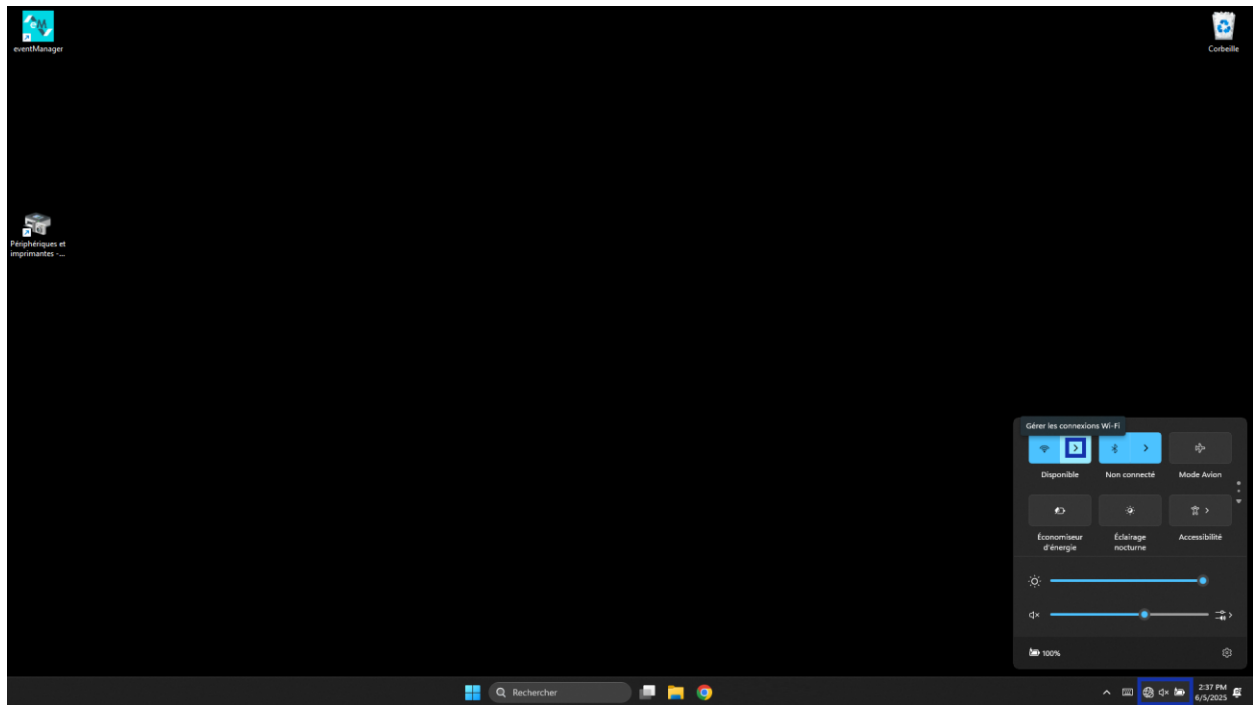

Select your Wi-Fi, enter the password, and connect.

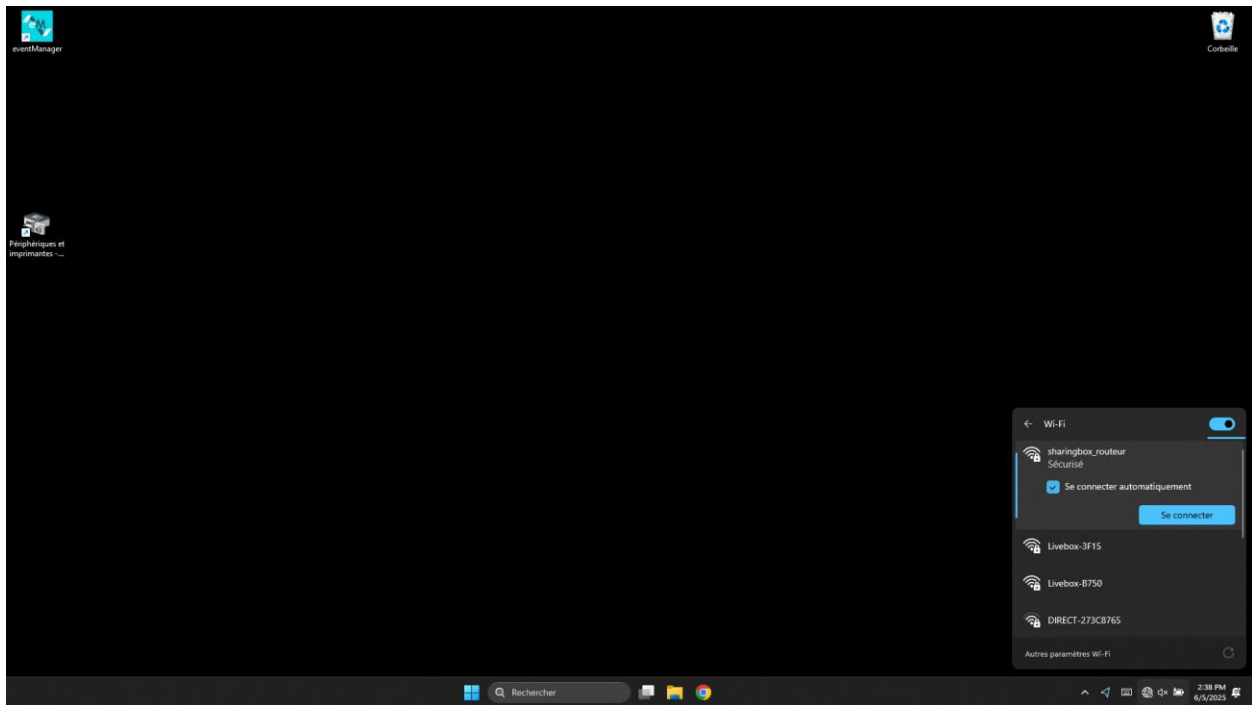

2.2) Windows updates

To make the most of our software, please ensure that your device is up to date beforehand.

Go to your Windows menu and search/click on "Settings"

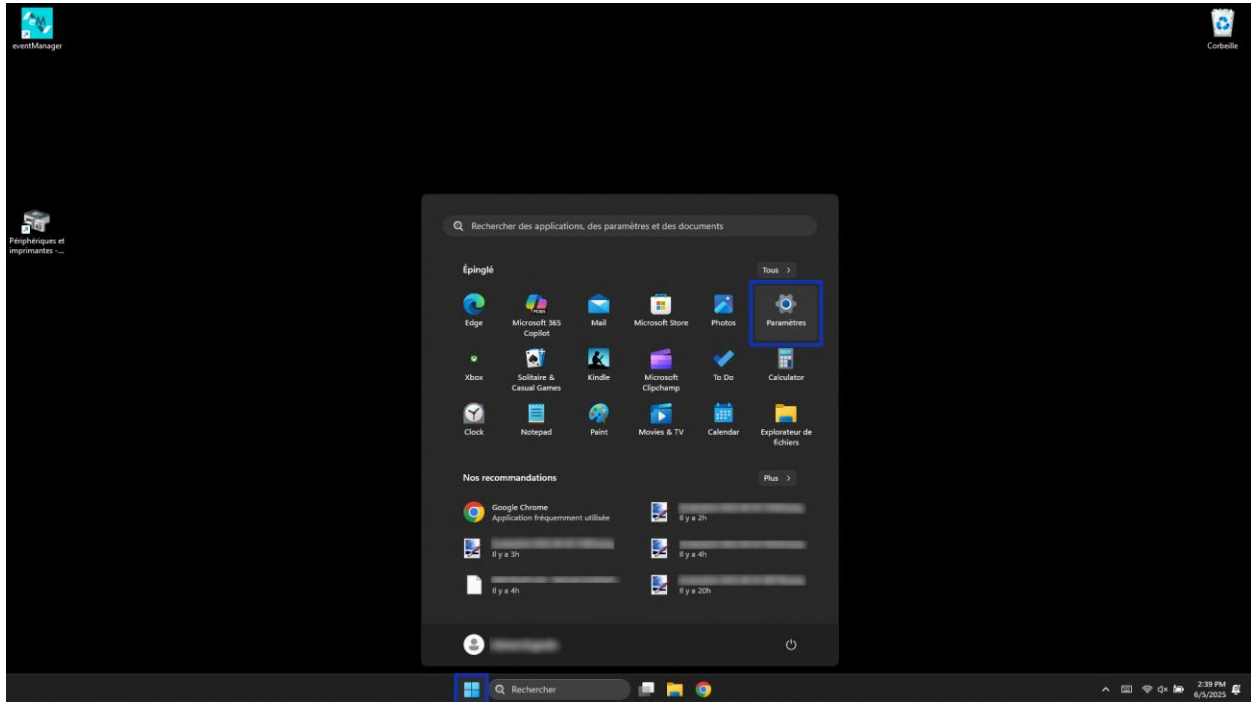

In your Windows settings, go to the "Windows Update" tab and start searching for updates.

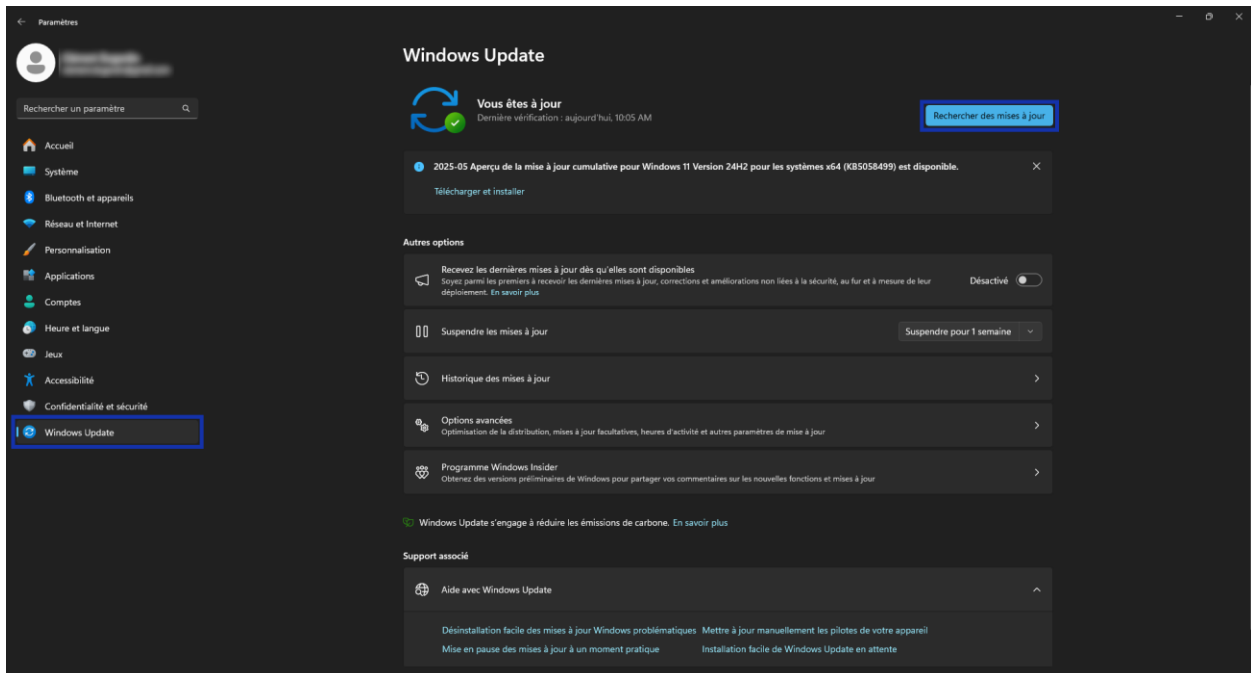

Install all the available updates, then repeat the process until there are no more updates available.

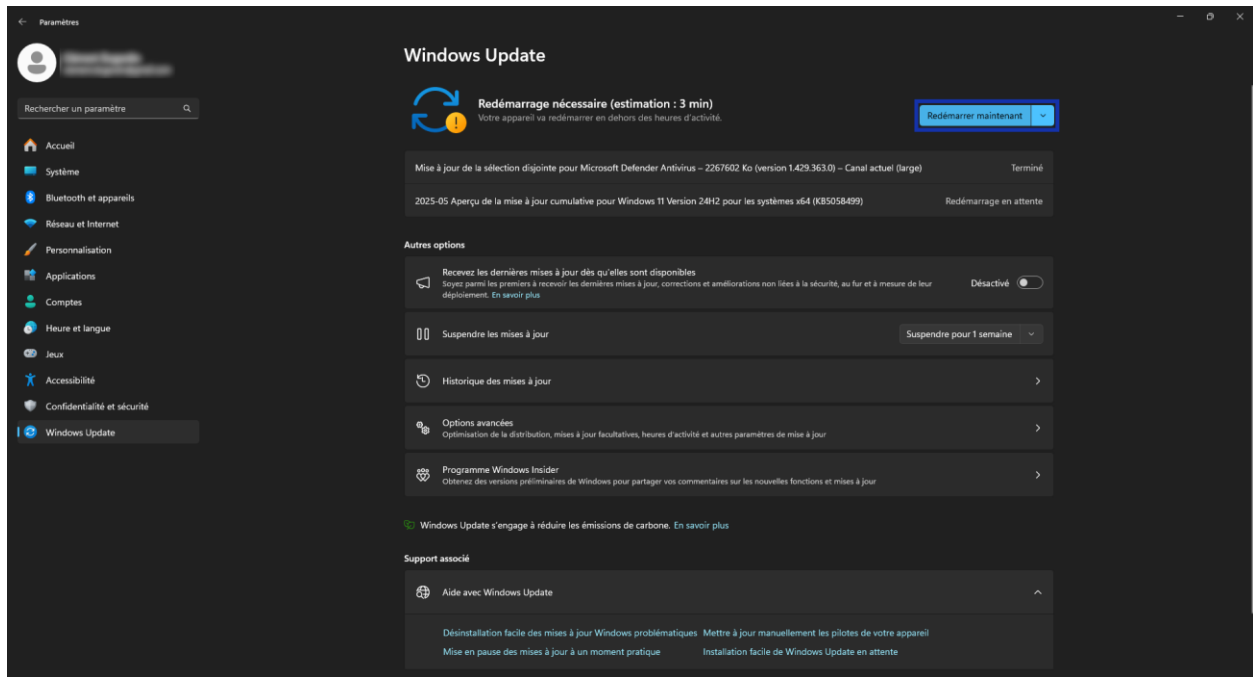

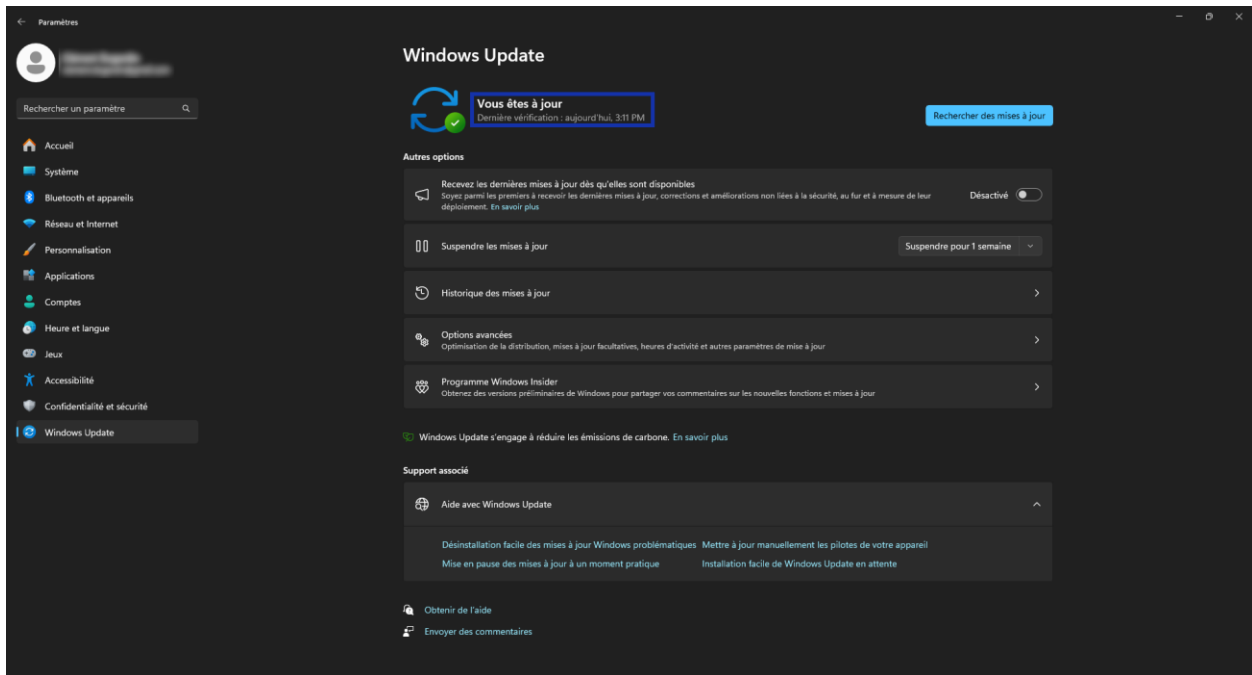

2.3) Software updates

Double-click on the eventManager software shortcut.

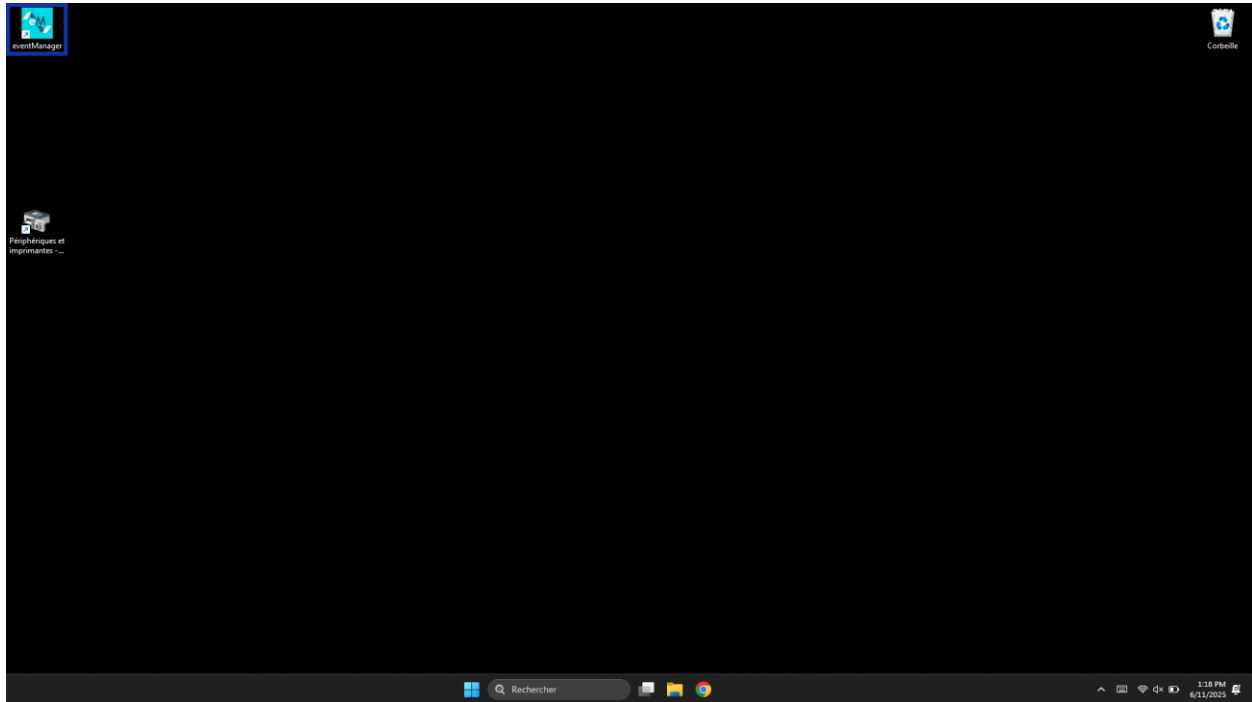

When it starts up, it should automatically open to the administration screen. Check the top right corner to see if the software update icon (the red bell) is available.

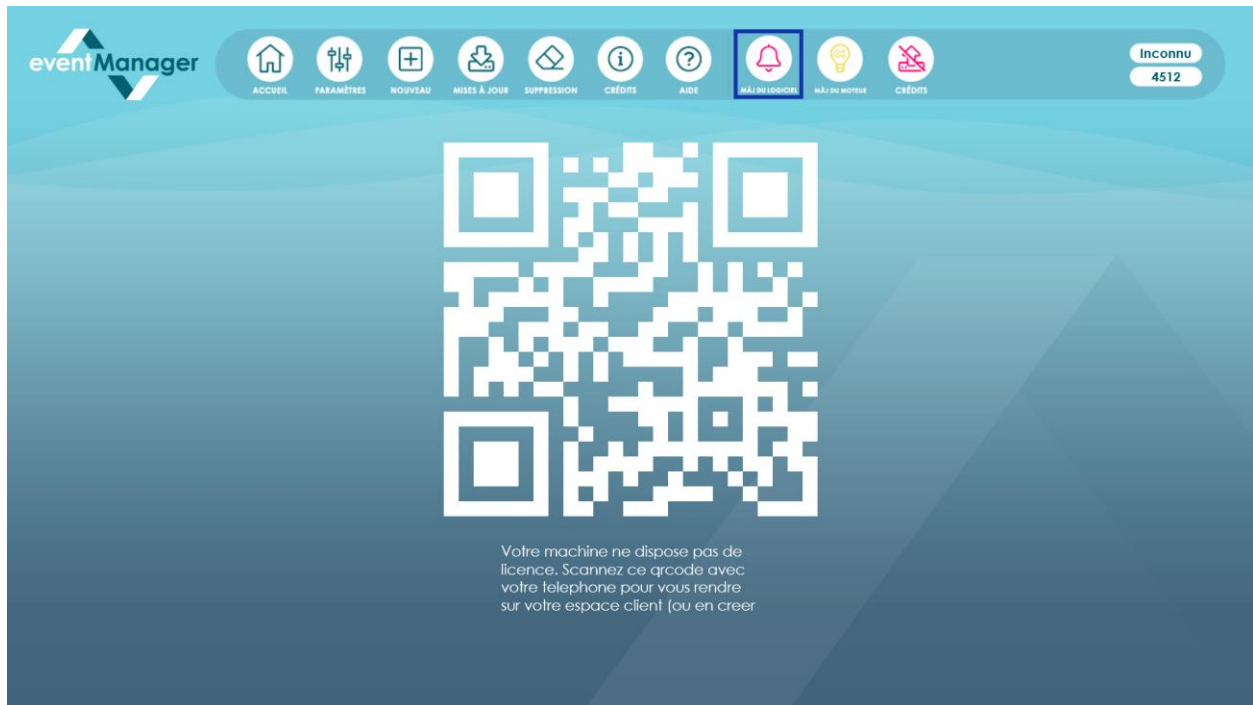

If this is the case, click on it to open the window and start the update procedure.

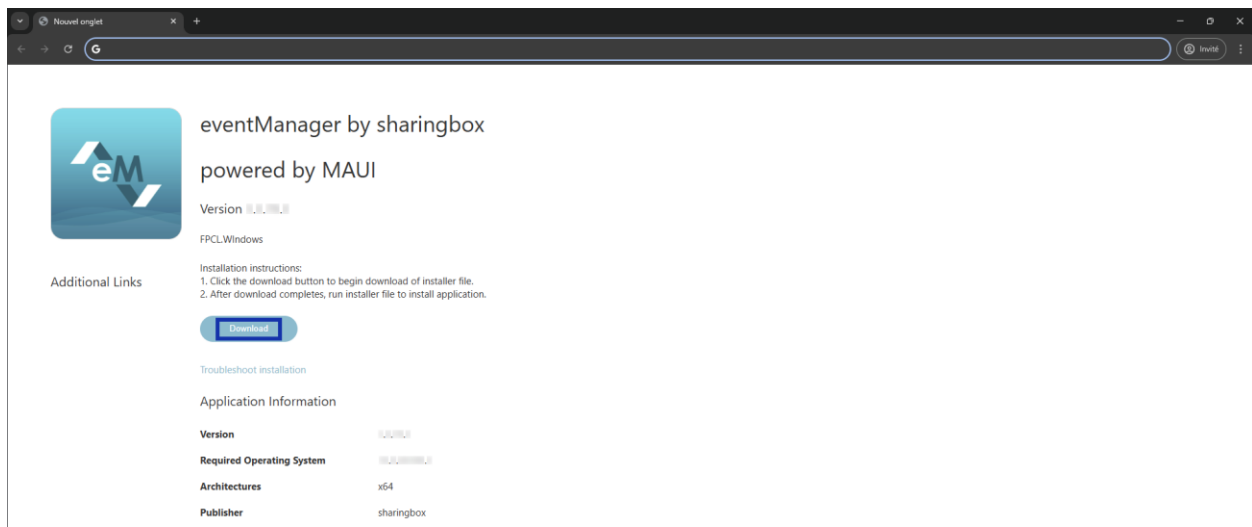
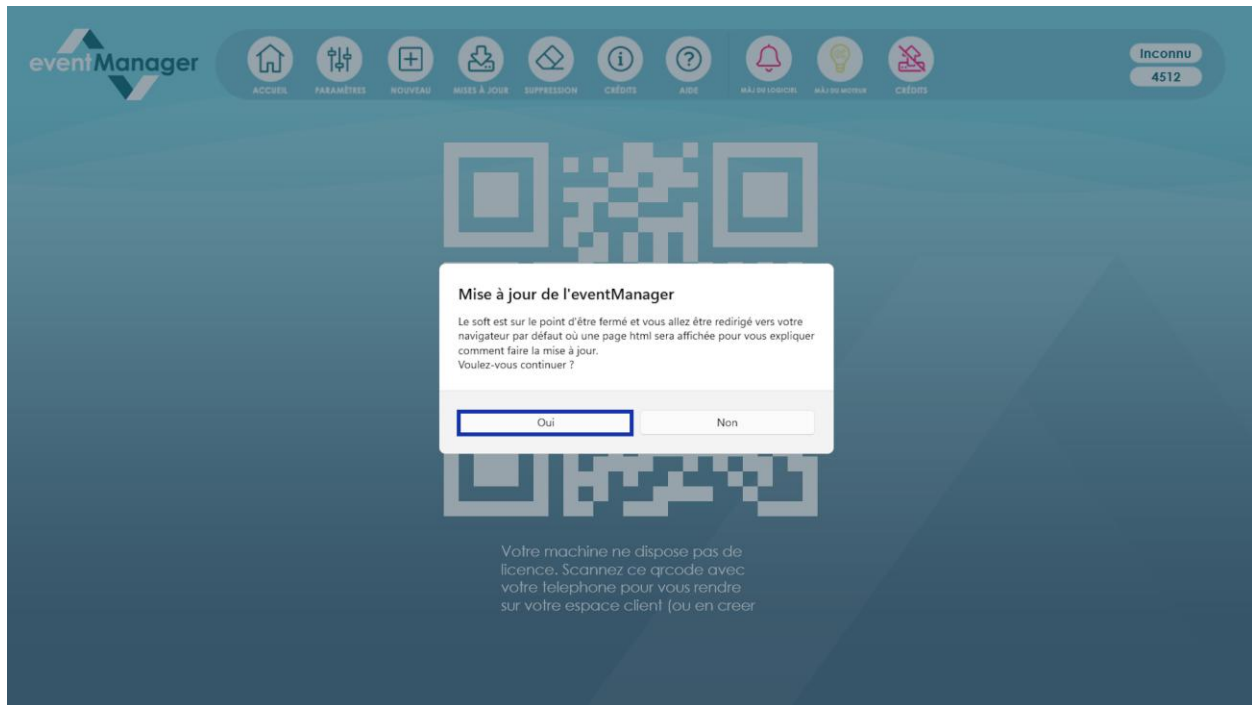

Once you've updated and restarted your software, make sure to update all the software components by clicking the "Updates" button.



STEP 3: CREATE AN ACCOUNT AND LINK IT TO THE PHOTOBOOTH

3.1) Create your account

Now that you're connected to the Wi-Fi, you can start linking the device to an account. To do this, simply scan the displayed QR code. You'll be directed to a link on your phone where you can create an account that will be linked to the kiosk.



To get started, accept the cookies, click on "Create an account," enter your information, and then click the "Sign Up" button.

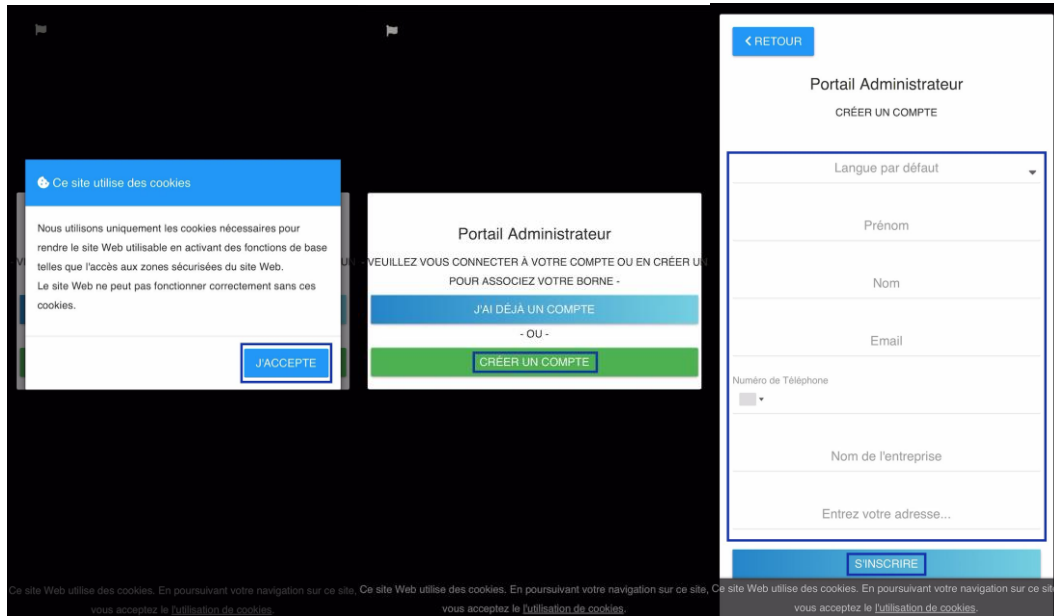

A message will appear after you sign up, letting you know that a welcome email has been sent to your inbox.

Please check your inbox to make sure you received the email. Don't forget to look in your spam or junk folder, just in case.

This one contains:

- Here's a link to access the *back office*, which is the main interface for creating events and managing your account.
- Your access code for the eventManager admin panel.
- A link that will take you to our complete documentation.

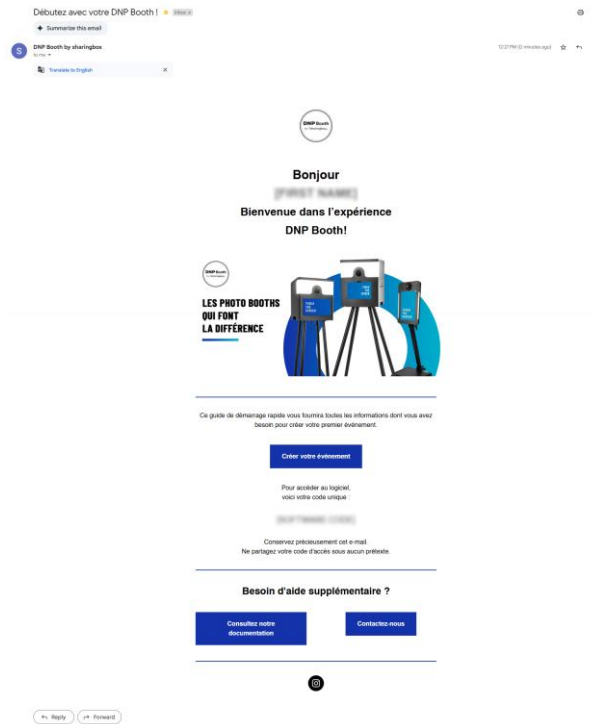

Note: Please remember to keep this email.

3.2) Logging into your account

We recommend using your own computer for this part until step 5.

Please go to the back office using this web address: <https://bo.dnpbooth.com/login> ([you can find the link in](#) the welcome email you received).

Please accept the cookies necessary for using the interface.

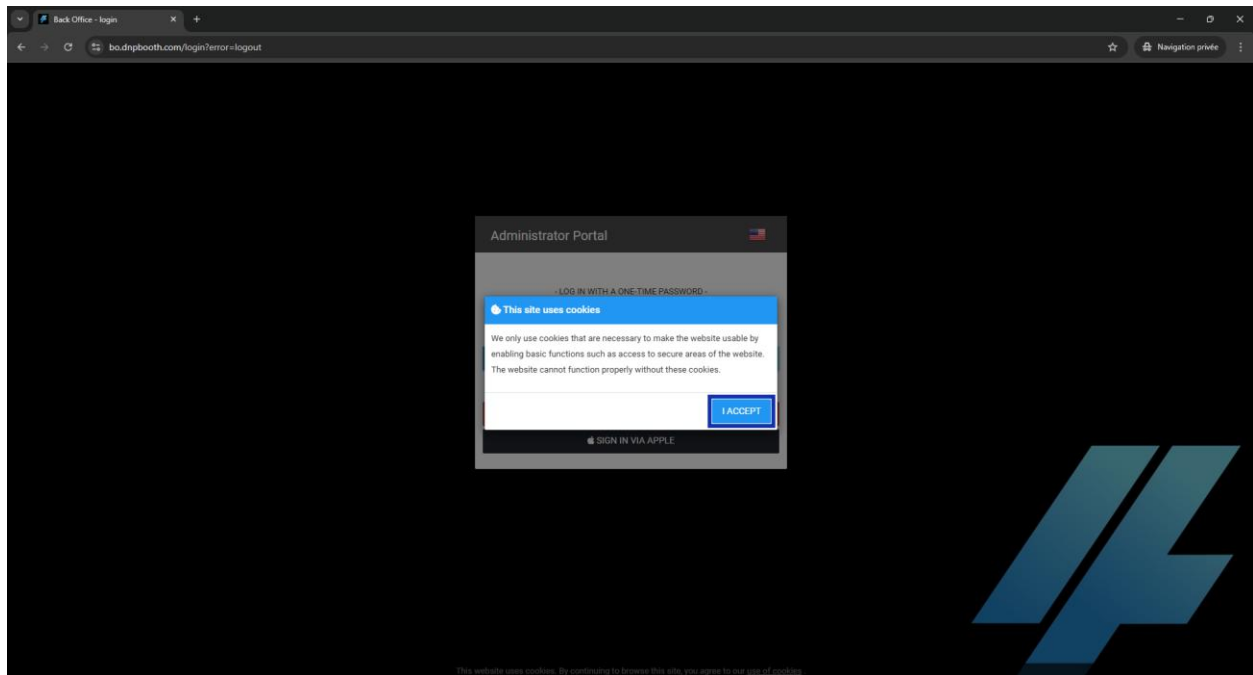

Then log in:

- You can log in using the buttons based on whether your email address is linked to a Google account (Gmail) or an Apple account (iCloud).
- You will receive a one-time password via email, so please check your inbox (and don't forget to look in your spam or junk folder).

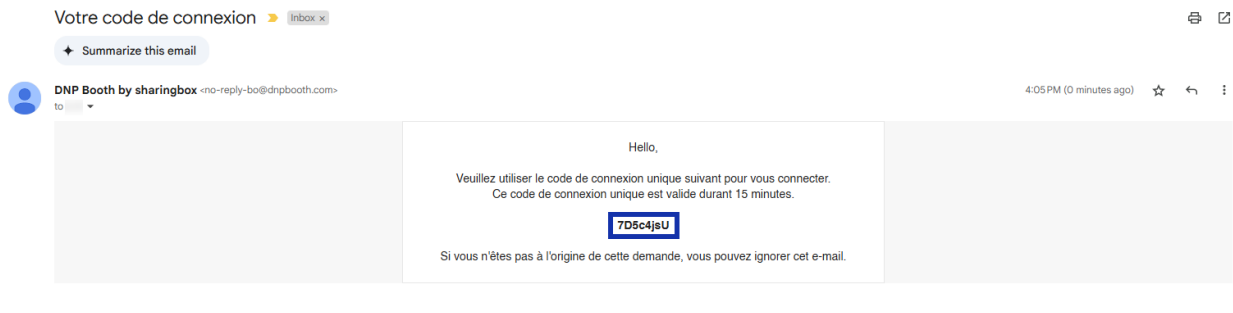
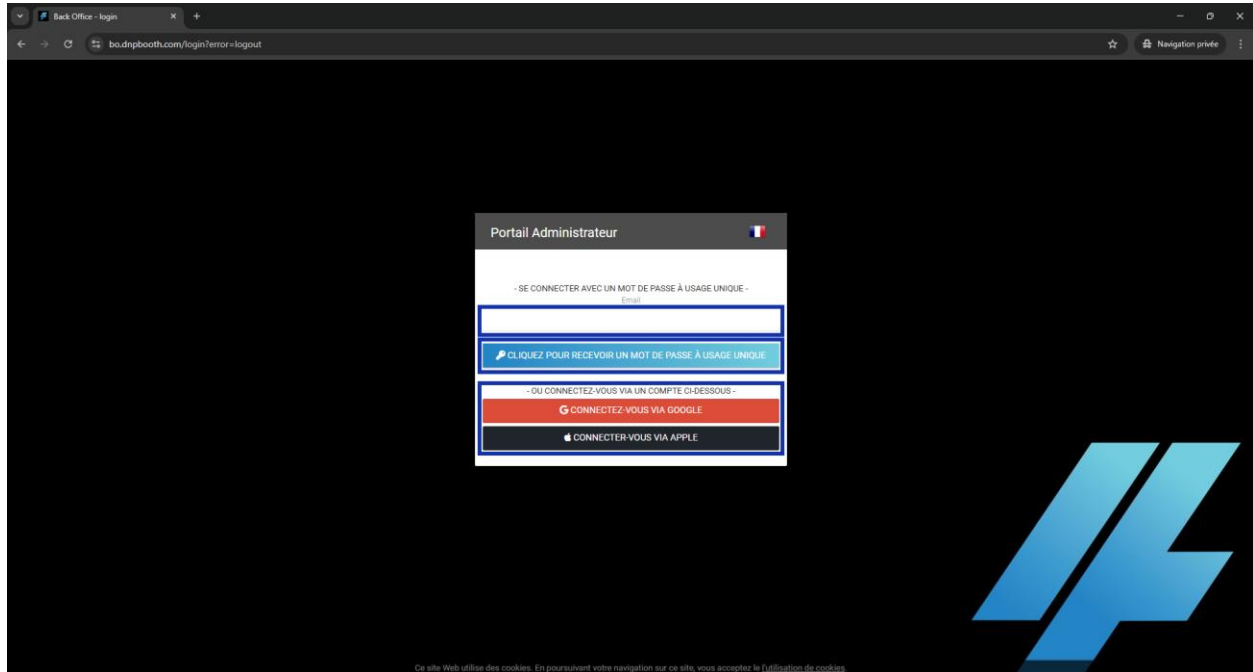

You are now logged into the back office and have a BASIC license by default, which will allow you to create simple events.

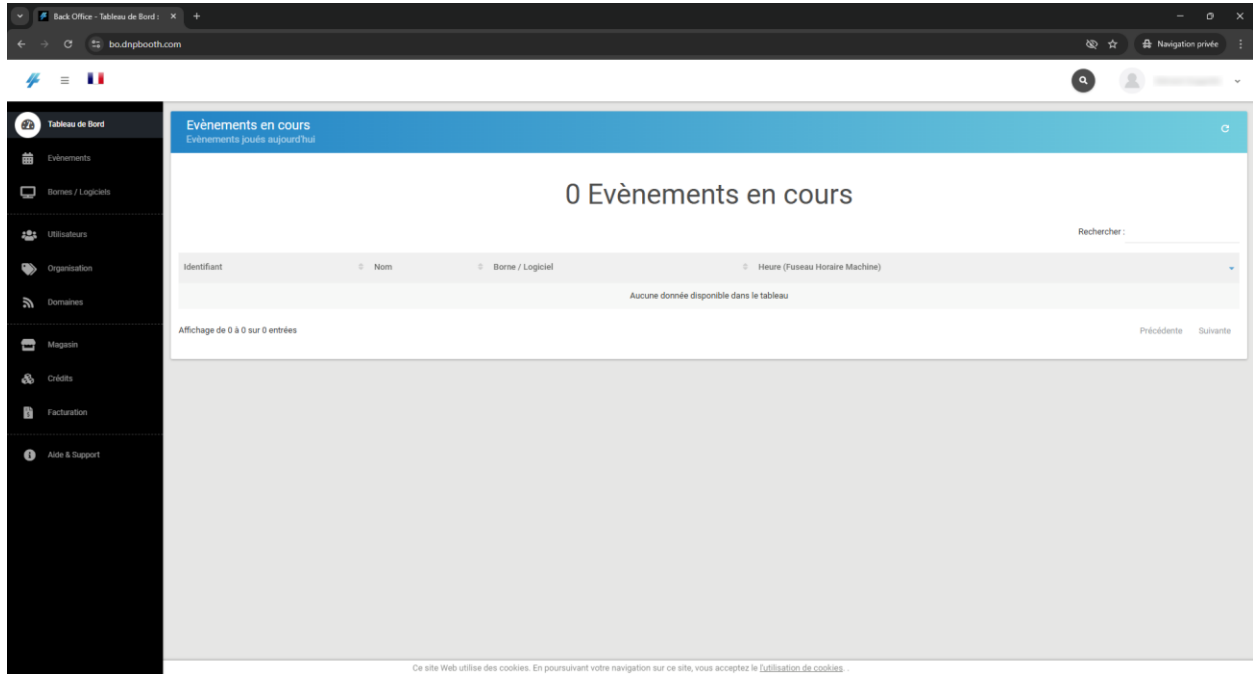

STEP 4: CREATE AND CONFIGURE AN EVENT

4.1) Create an event

NOTE: To create an event, you must be logged into the back office.

Go to the "Events" menu and click on "New" to open the event creation page.

2. Enter the details of your event, including its name, start date and time, and end date and time, then click the "Create" button.

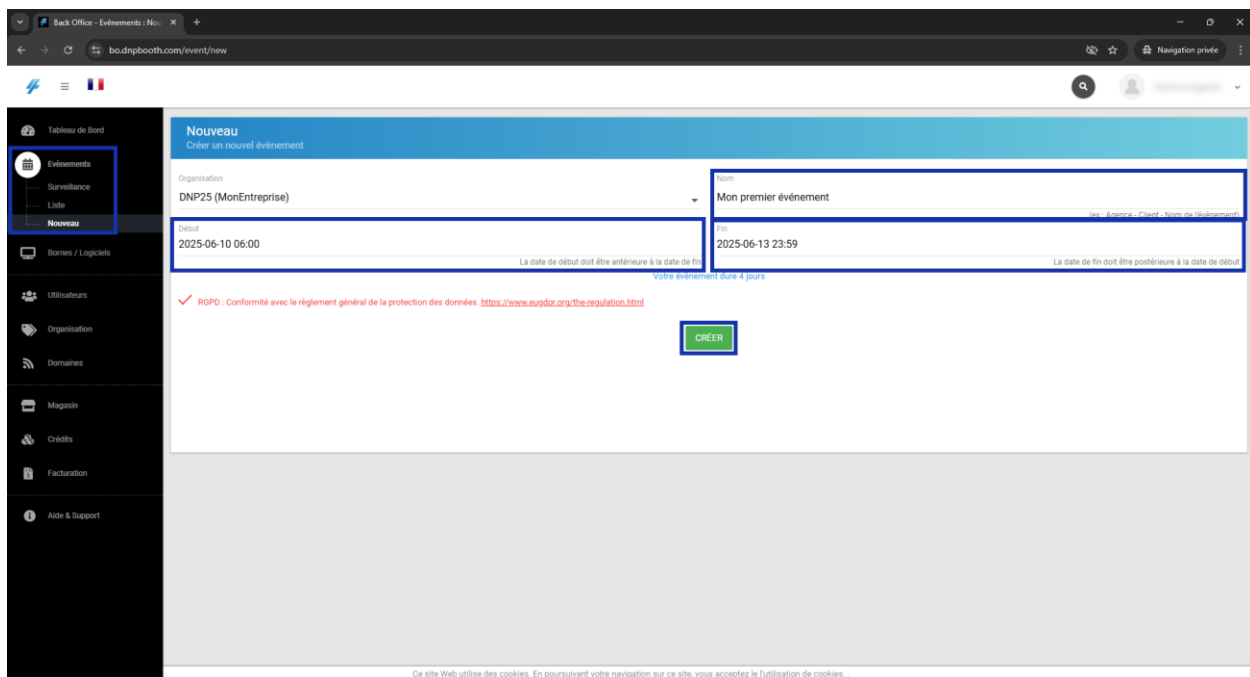

With each event creation, is created:

- An event identifier (*event ID*)
- An event space dedicated (*interface event-space*)
- A dedicated configuration space (*event-editor interface*)

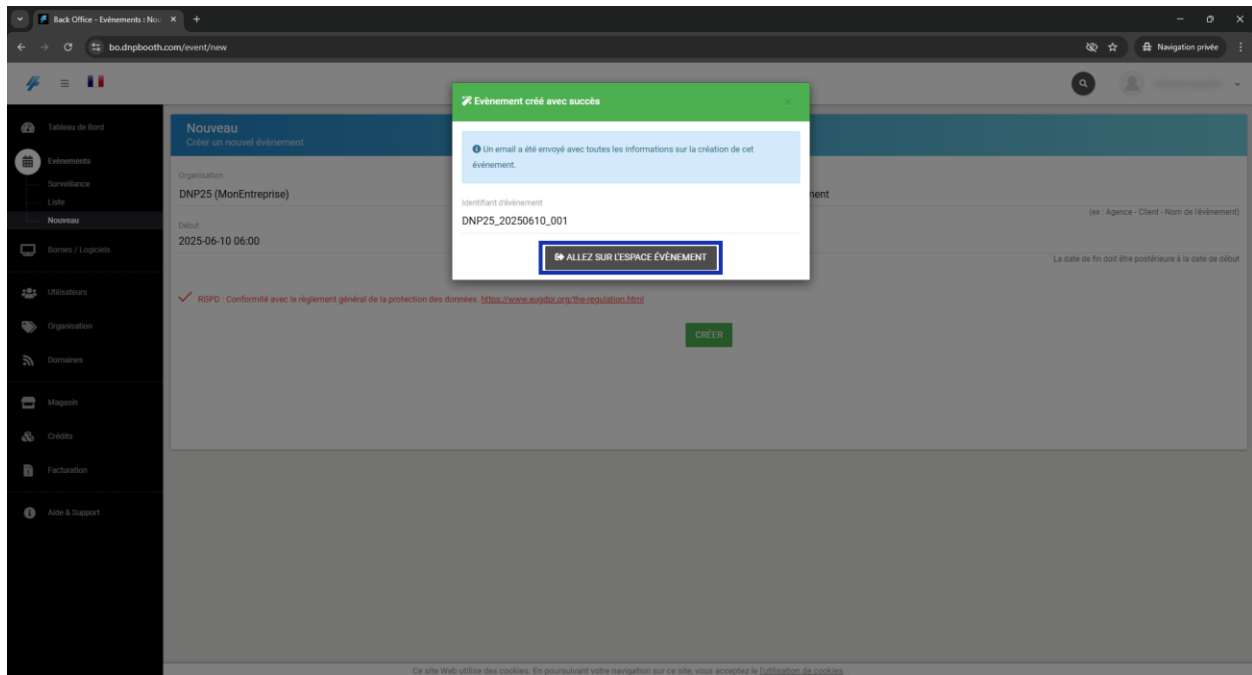

The identifier of your event is made up of 3 parts:

- Your license identifier
- The start date of your event
- An incremental number to identify your event.

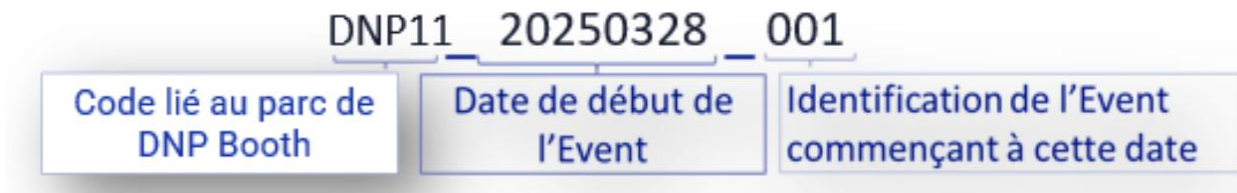

You will receive a confirmation email after the event is created, which will include the *event ID*, as well as the *start and end times of the event*.

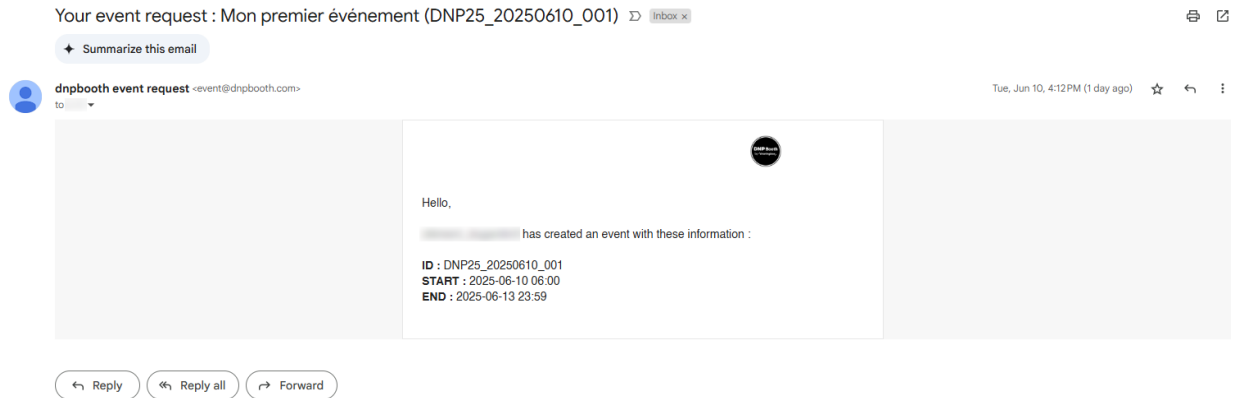

4. You must then go to your event space. For this, there are 2 methods:

- Either directly via the button displayed after creating your event.

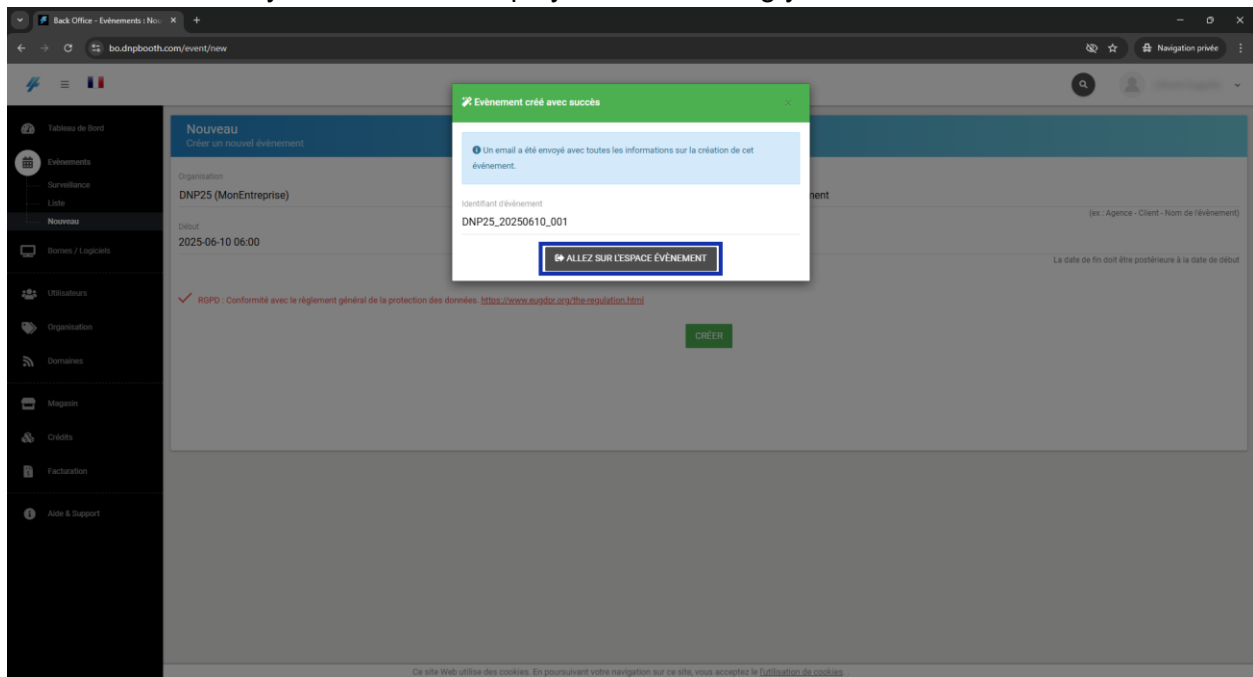

- In the back office, go to the "Events" menu, click on "List," find your event, and then click on the icon to the left of its ID.

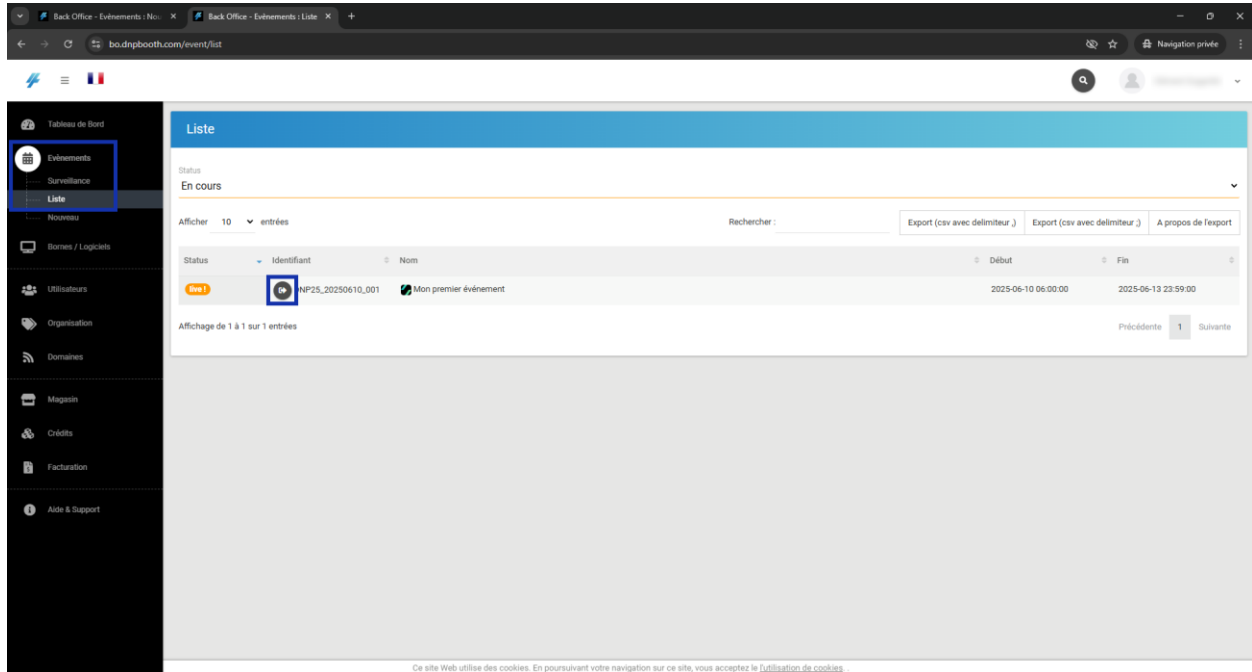

Note: For the second method, if you can't find your event right away, make sure to use the correct filter in the "Status" section at the top of the page.

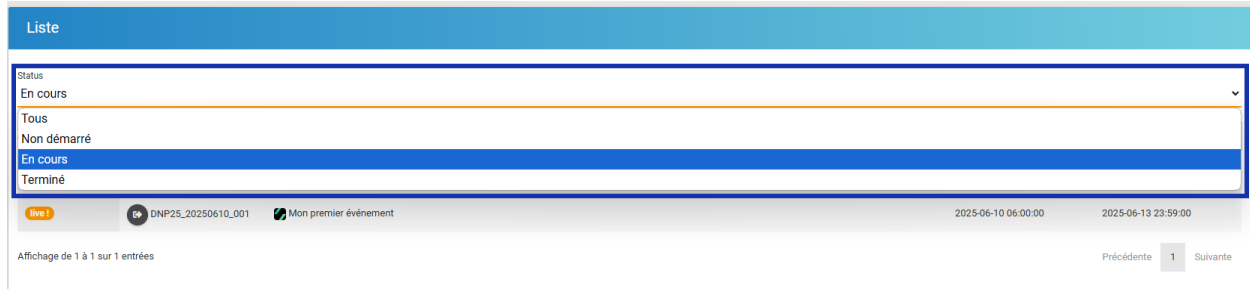

4.2) Configure your event

4.2.1) Selection of your event type

Once you're in your event space, click on the "Configuration" tab on the left side, and then hit the "Open Configuration Editor" button. This will take you to the event editor interface specifically for your event.

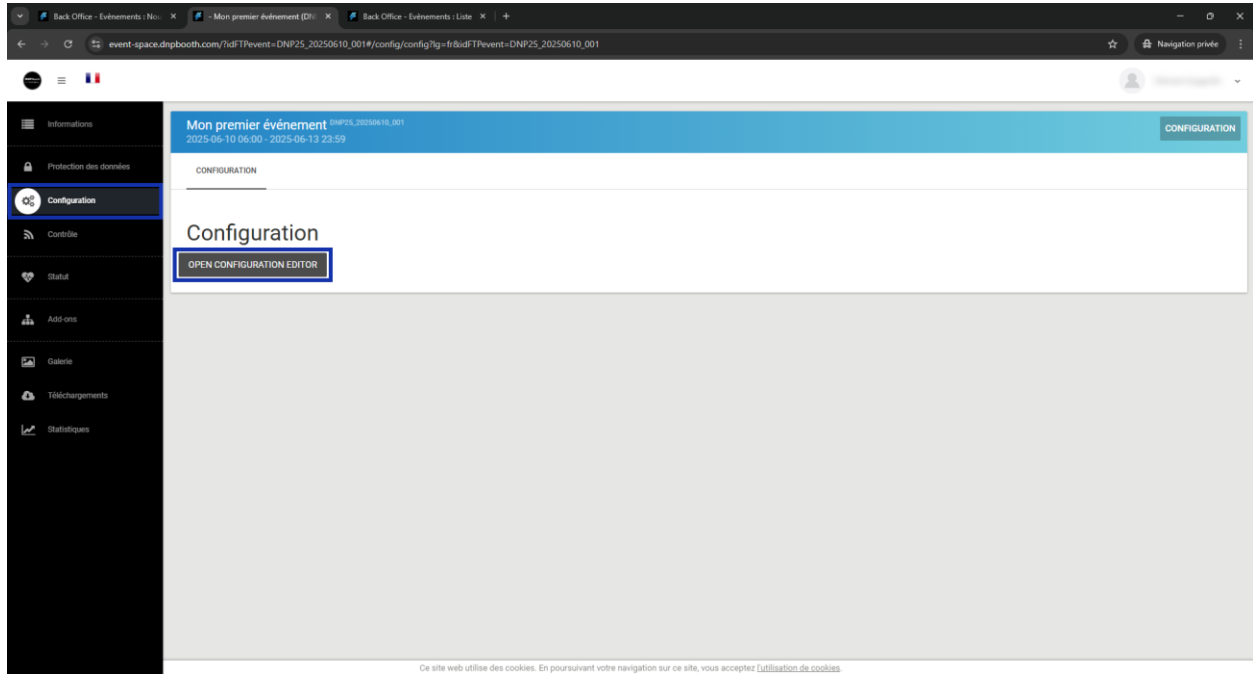

Click the "Set Up My Event" button to get started and explore the available configuration options.

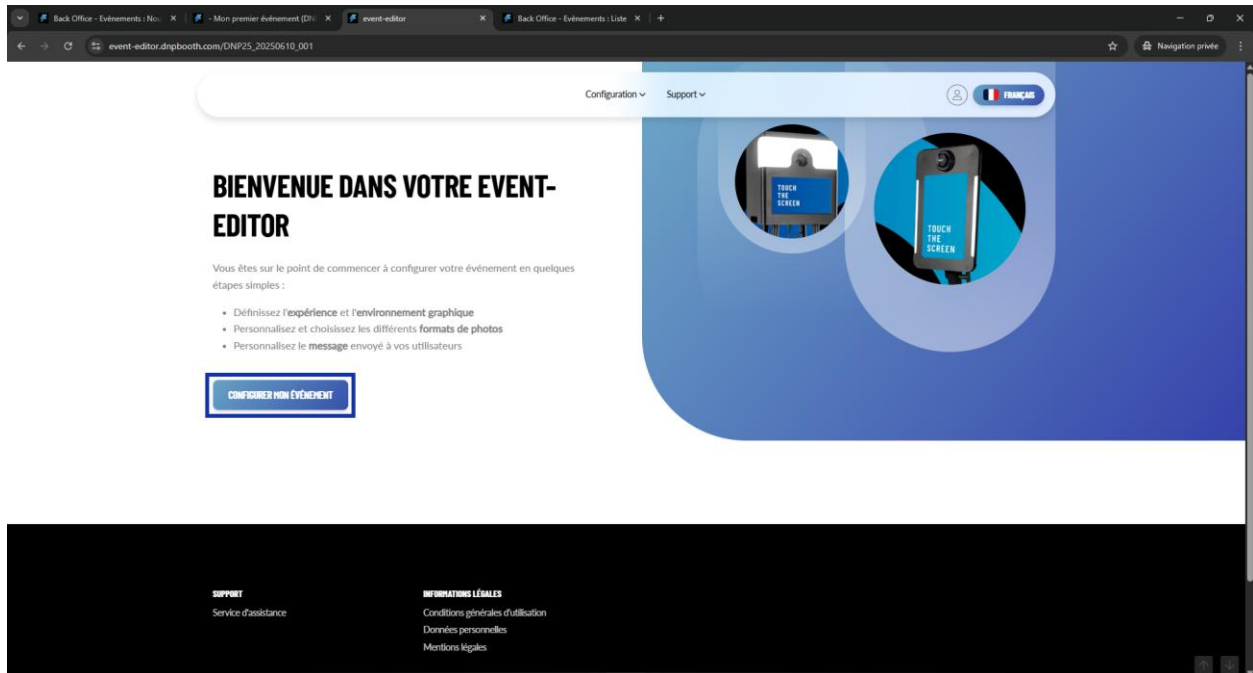

When you set up your event for the first time, you'll have the option to choose between two types of events:

- **Themes:**
For private events, you can choose from the private catalog and only enter specific details based on the type of event you select.
- **MODELS:**
Commonly used for corporate events, you can choose a standard event template here and customize the design and specific configuration options based on the selected preset.

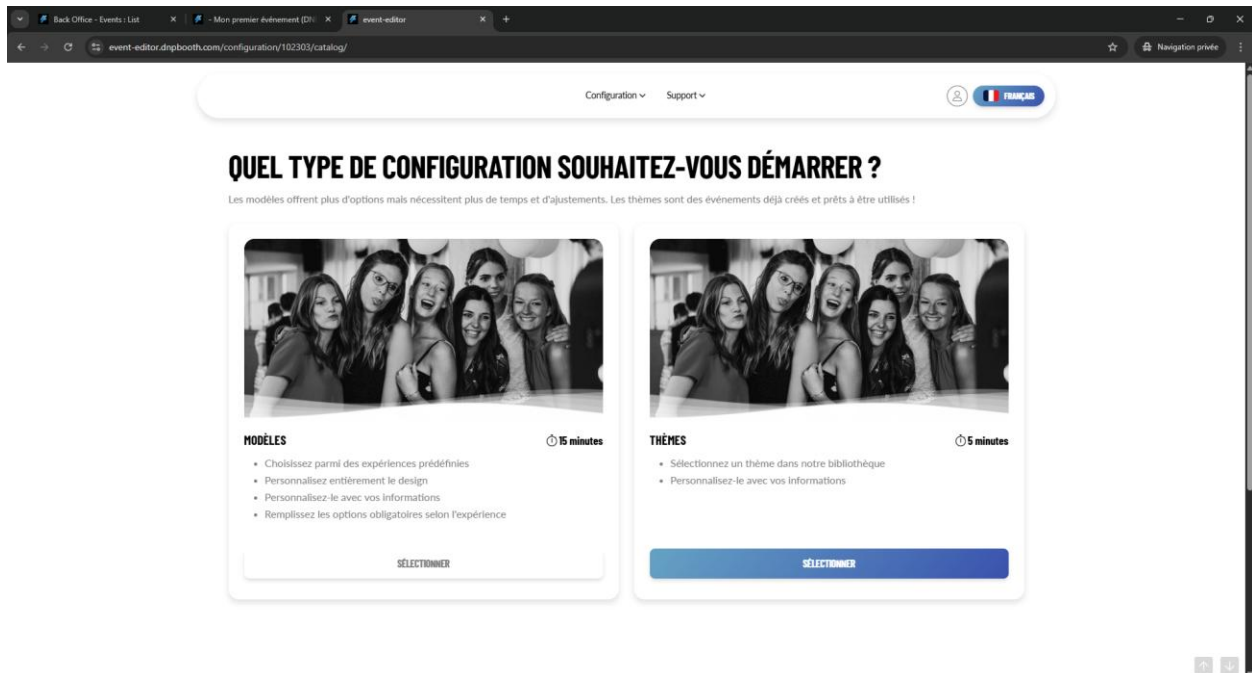

Now, we will explain how to set up a sample wedding event based on a theme.

Note: To learn how to set up an event based on a template, please refer to our more detailed documentation at <https://www.dnpphoto.eu/fr/telechargements/manuels-brochures/manuals/dnp-booth-1>.

4.2.2) Configuration of your "theme" event

1. Click on the "Select" button in the themes area.

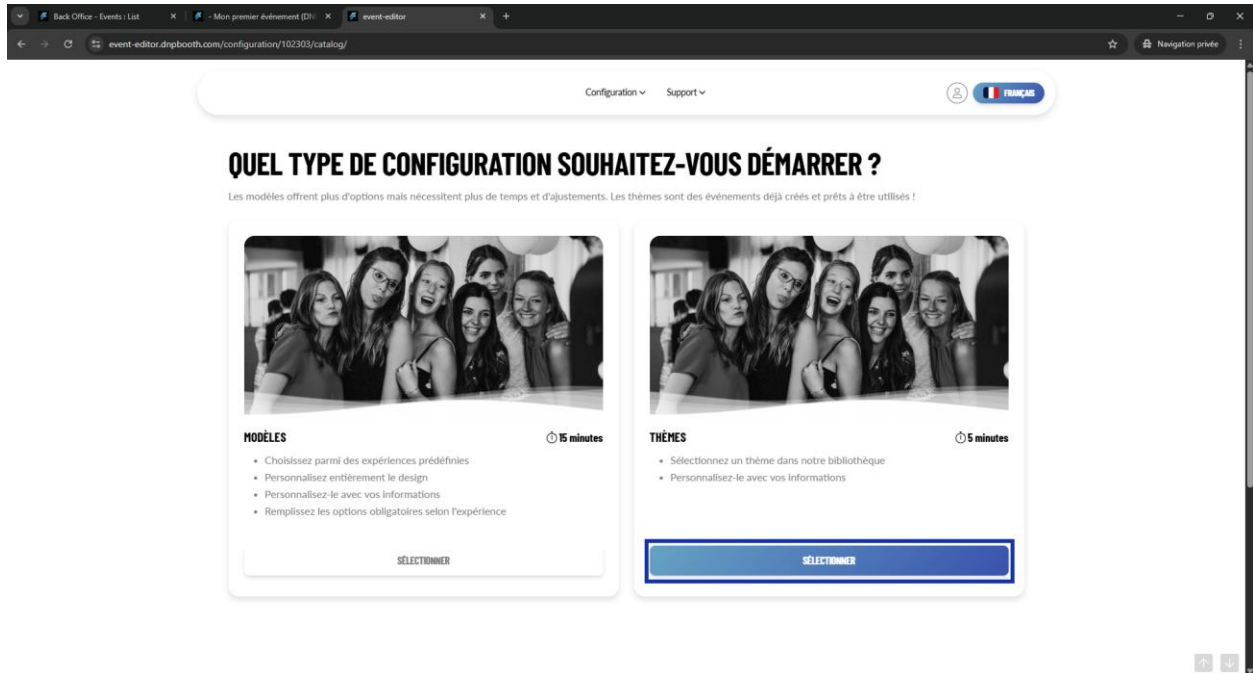

Click the “+” button next to the type of theme you want to set up, and then choose a theme.

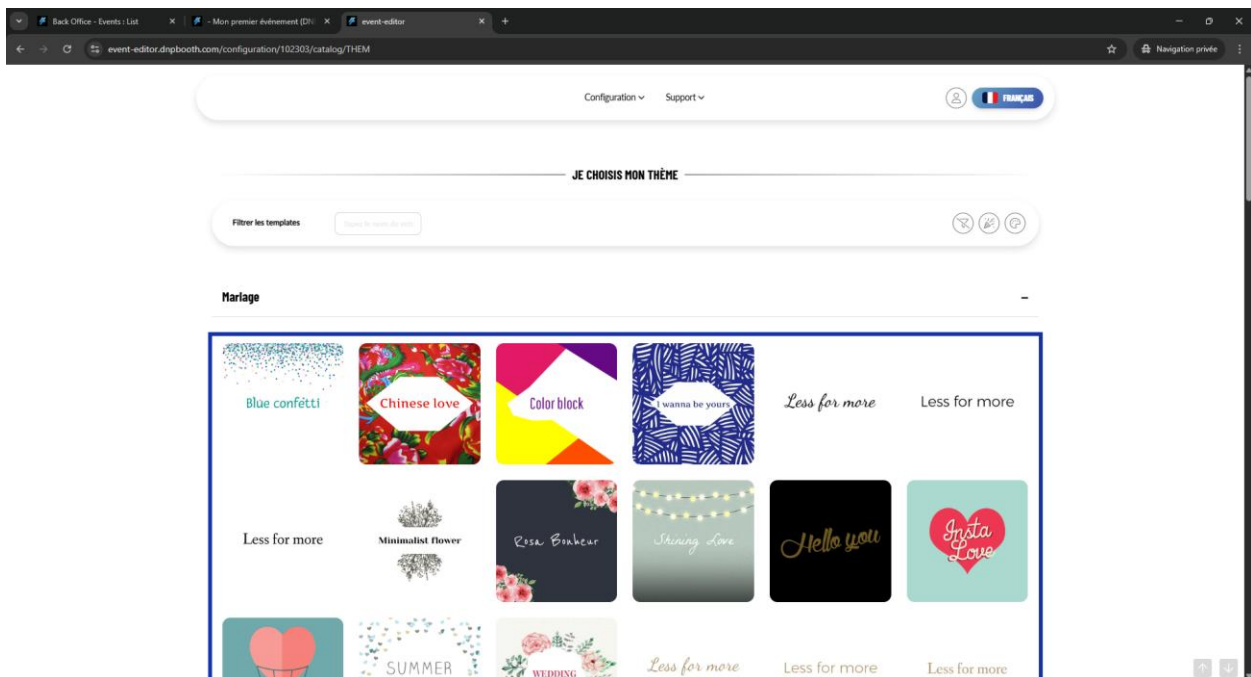
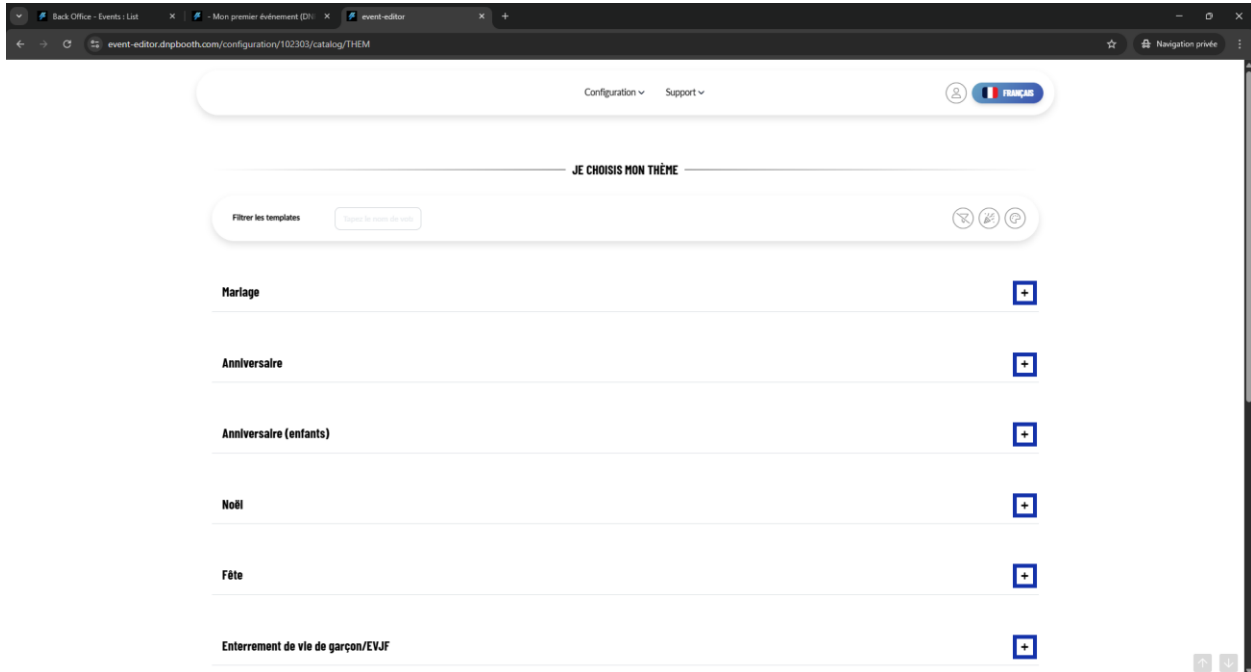

Once you've chosen your theme, you'll move on to setting up your event, which is organized into two main tabs:

- The editing of the elements of your event
- The editing of the textual parameters of your event

In the first tab, there are several sub-tabs:

- General: This section covers the key details of your event, such as the names of the couple getting married.
- Layouts: Here, you can choose which photo frames from your theme will be displayed at your event.
- Printing: This option allows you to set up automatic or manual printing, as well as limit the number of times a single photo can be printed.
- Languages: This section pertains to the language of the text displayed at your event.

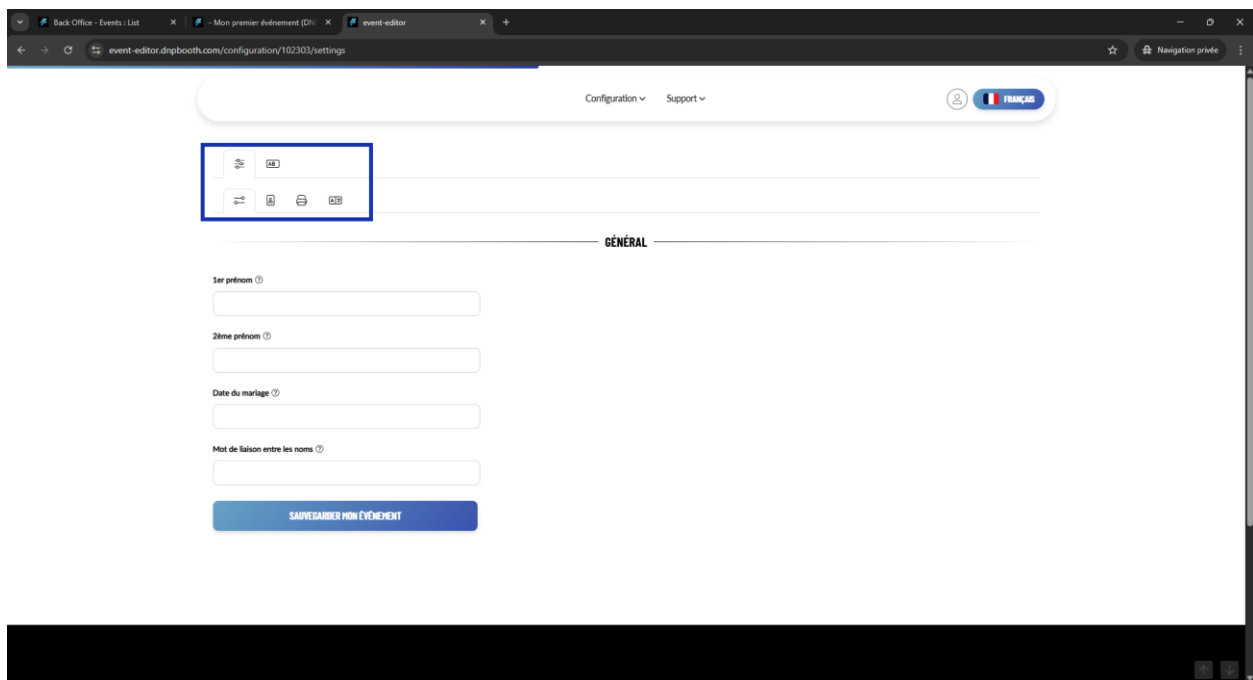

The screenshot shows a web browser window with the URL `event-editor.dnpbooth.com/configuration/102303/settings`. The page is titled "Configuration" and "Support" in the top right corner. A language selector shows "FRANÇAIS". A blue box highlights a menu with icons for "GÉNÉRAL", "LAYOUTS", "IMPRESSION", and "LANGUES". Below this, the "GÉNÉRAL" section is active, featuring four input fields: "1er prénom", "2ème prénom", "Date du mariage", and "Mot de liaison entre les noms". A blue button labeled "SAUVEGARDER MON ÉVÈNEMENT" is at the bottom.

4. Fill in the general information in the "General" menu.

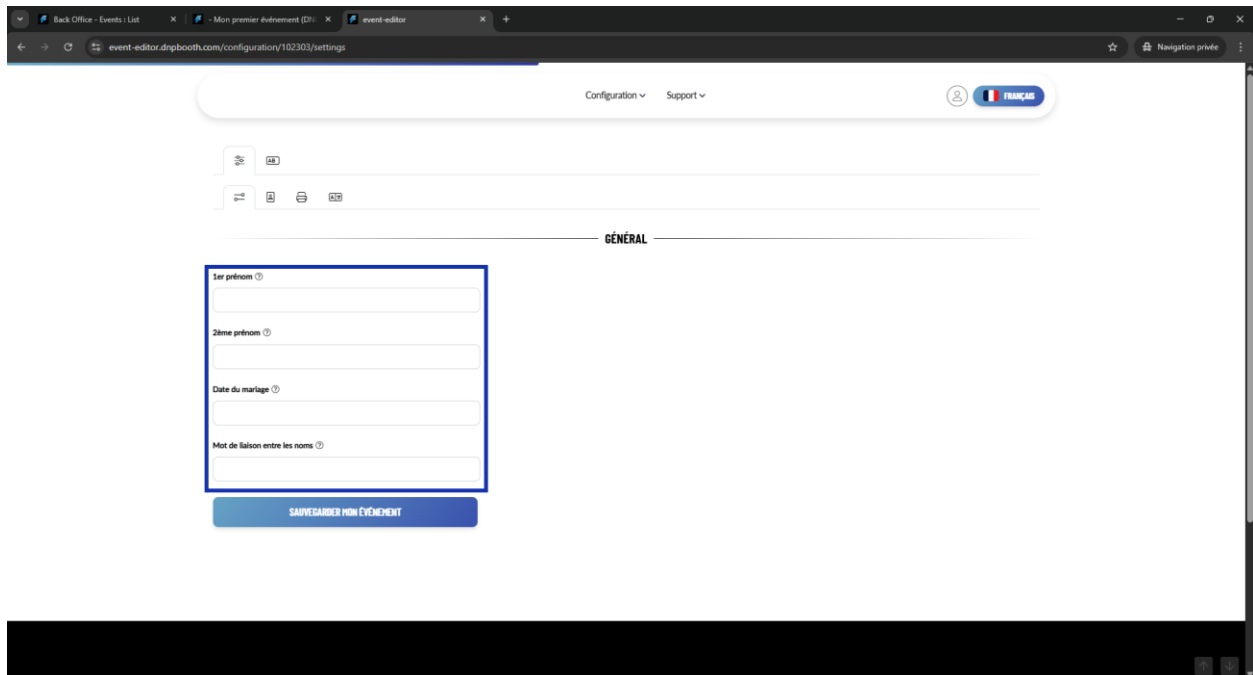

5. Choose your photo frames from the "Layout" menu, then click on "Add." You can include up to 15 photo frames in a single event.

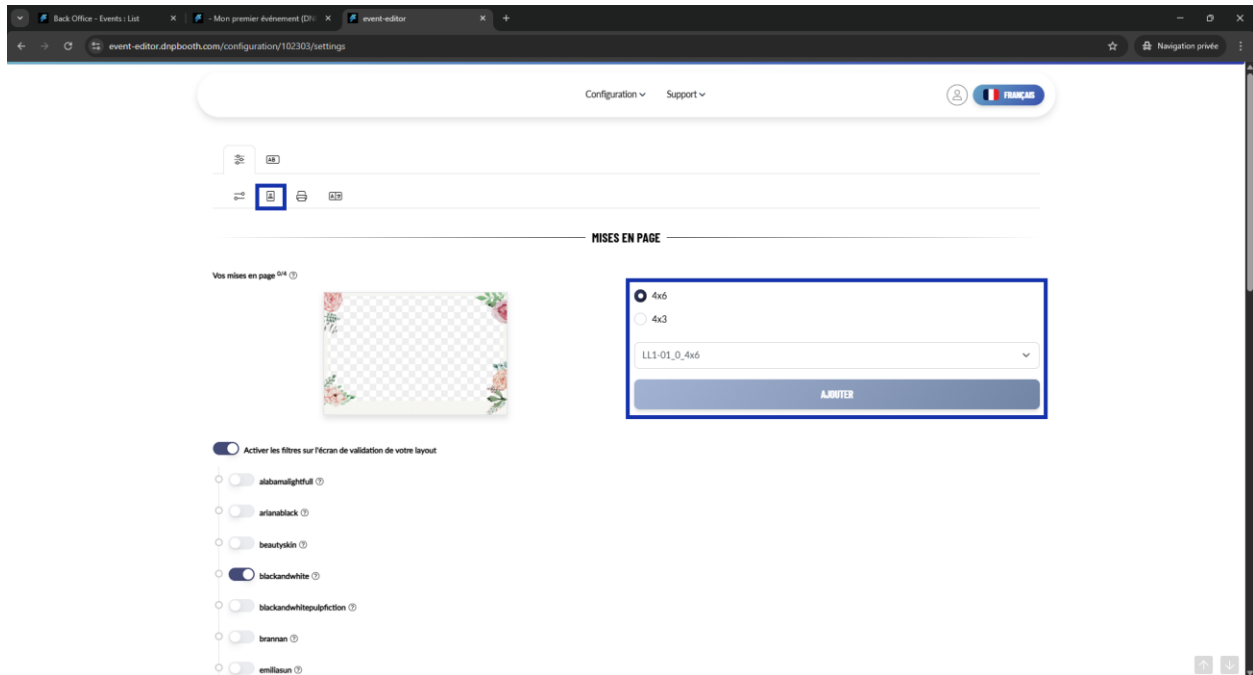

For each added frame, a summary table appears with options, along with a download area that features a dedicated action button on the right side. This button lets you edit your frame by adding text and images, as well as adjusting the positions and sizes of the elements you added earlier.

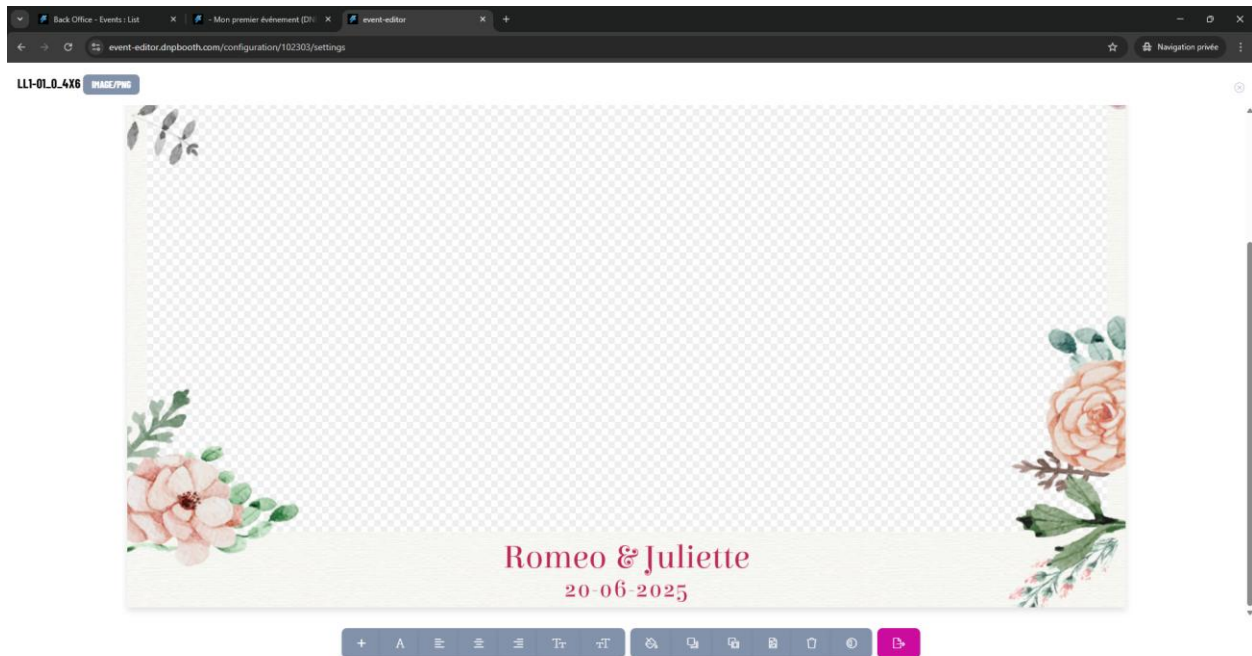
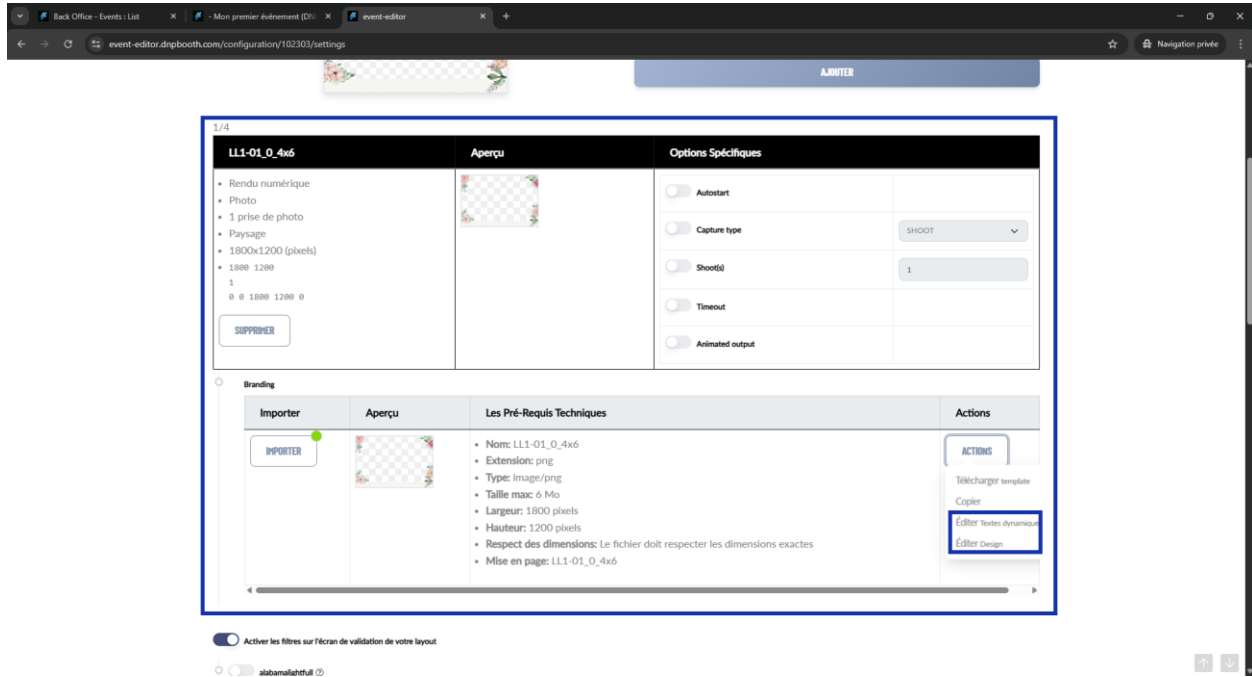



At the bottom of this tab, you can choose the filters that will be available for users to select during your event. We recommend using a maximum of 5 filters at the same time.

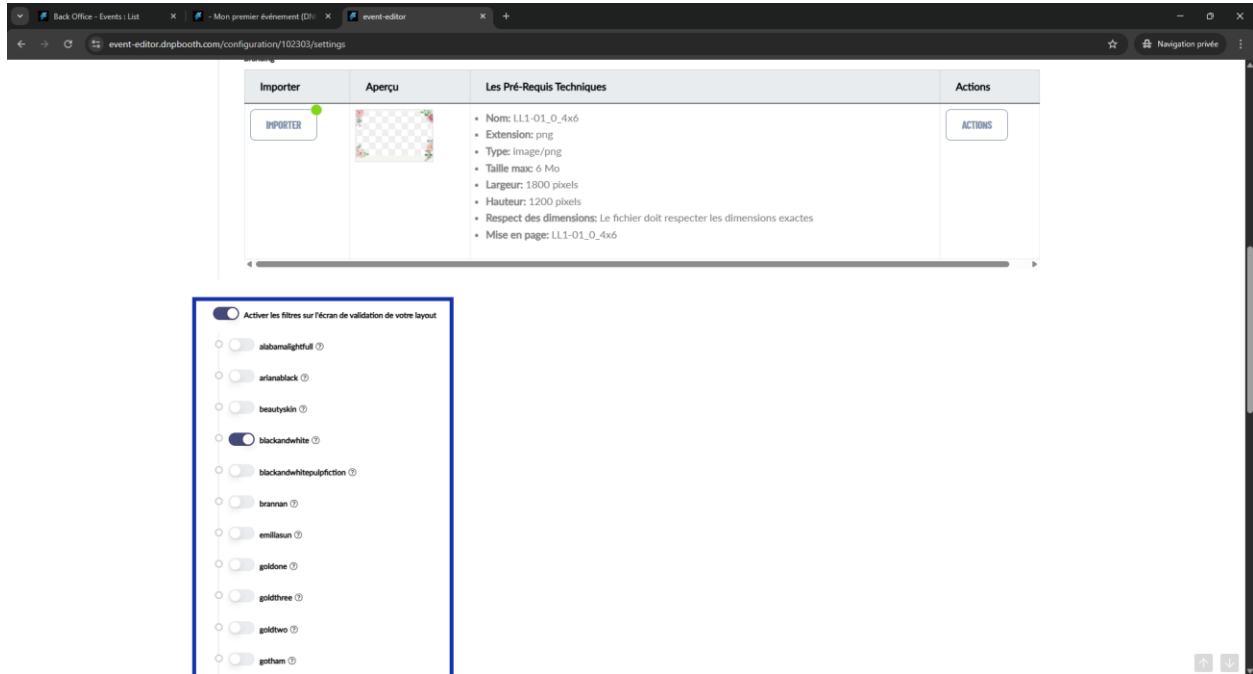

By default, printing is set to user preference, but you can change this in the "Print" menu. You can also increase the maximum number of prints available for your event.

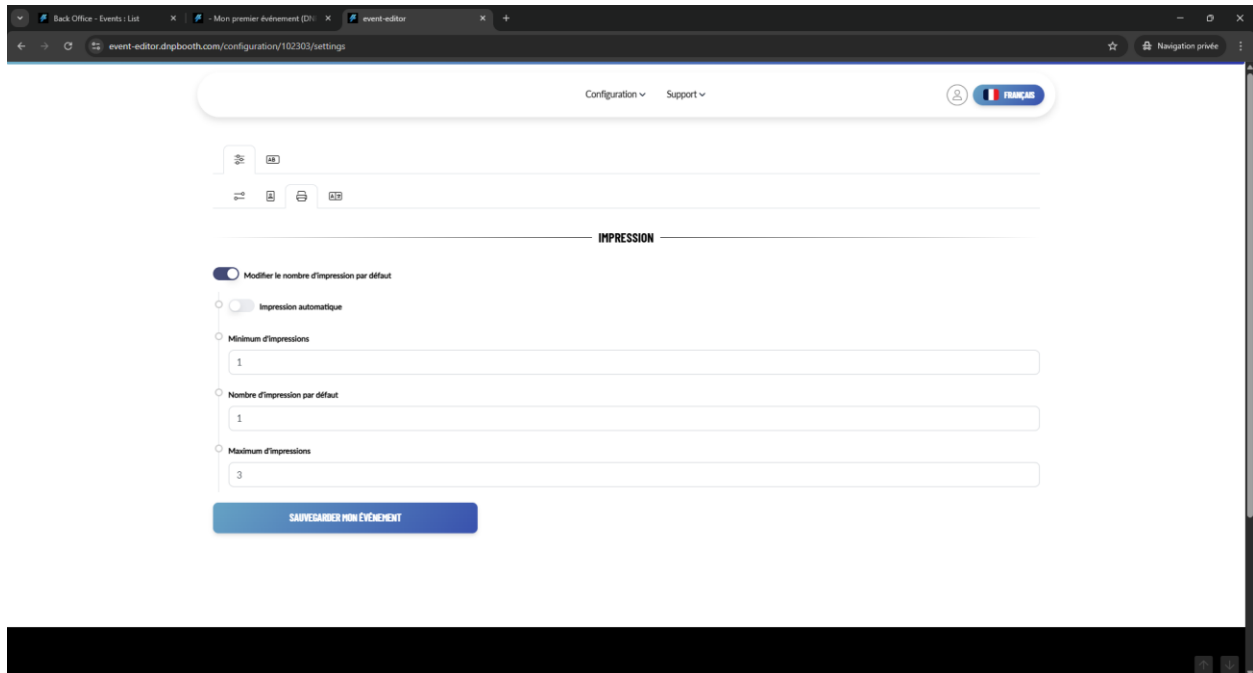

Finally, you can choose the default language for your event and offer up to three additional languages.

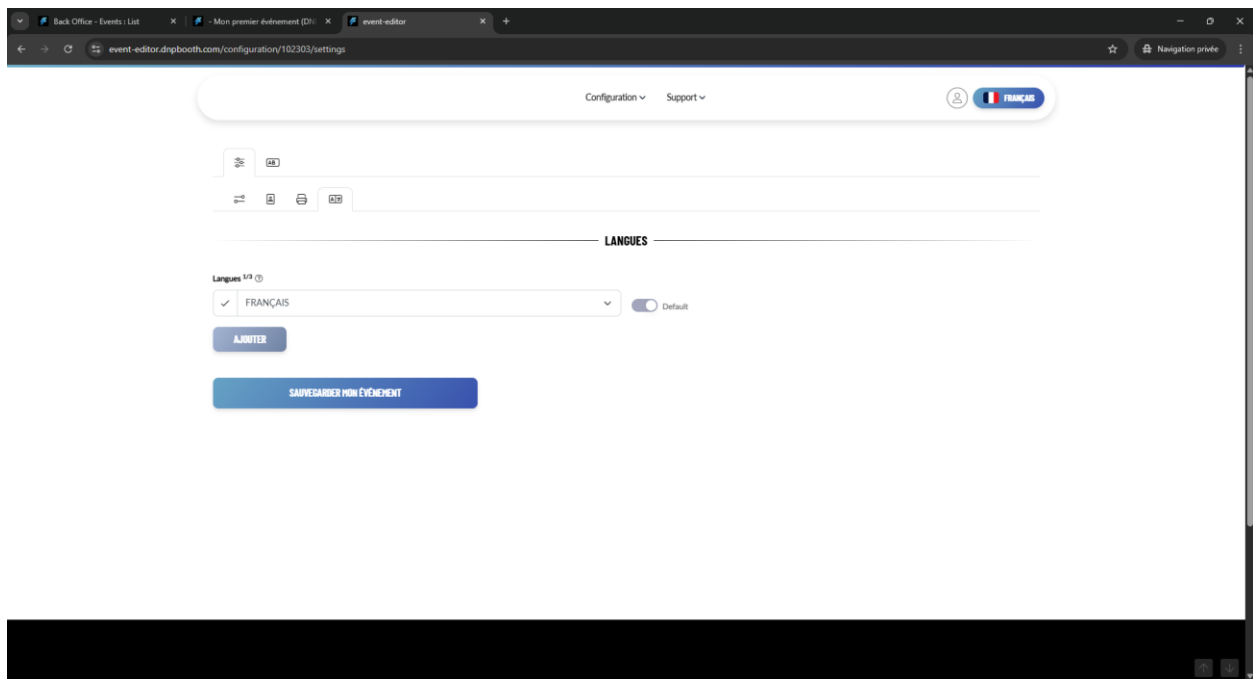

If you need to change any text, you can do so in the Text Settings tab.

IMPORTANT: Please note that if you change the language after modifying your settings. Textual, all your changes will be lost!

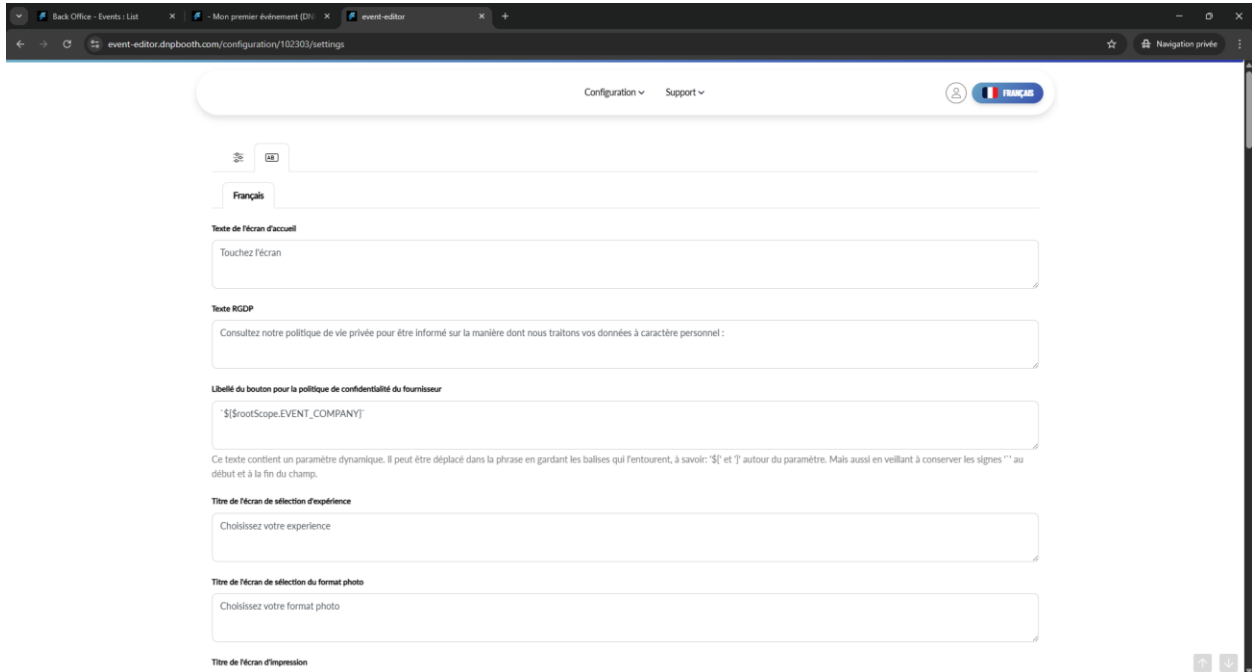

10. Save your configuration once completed.

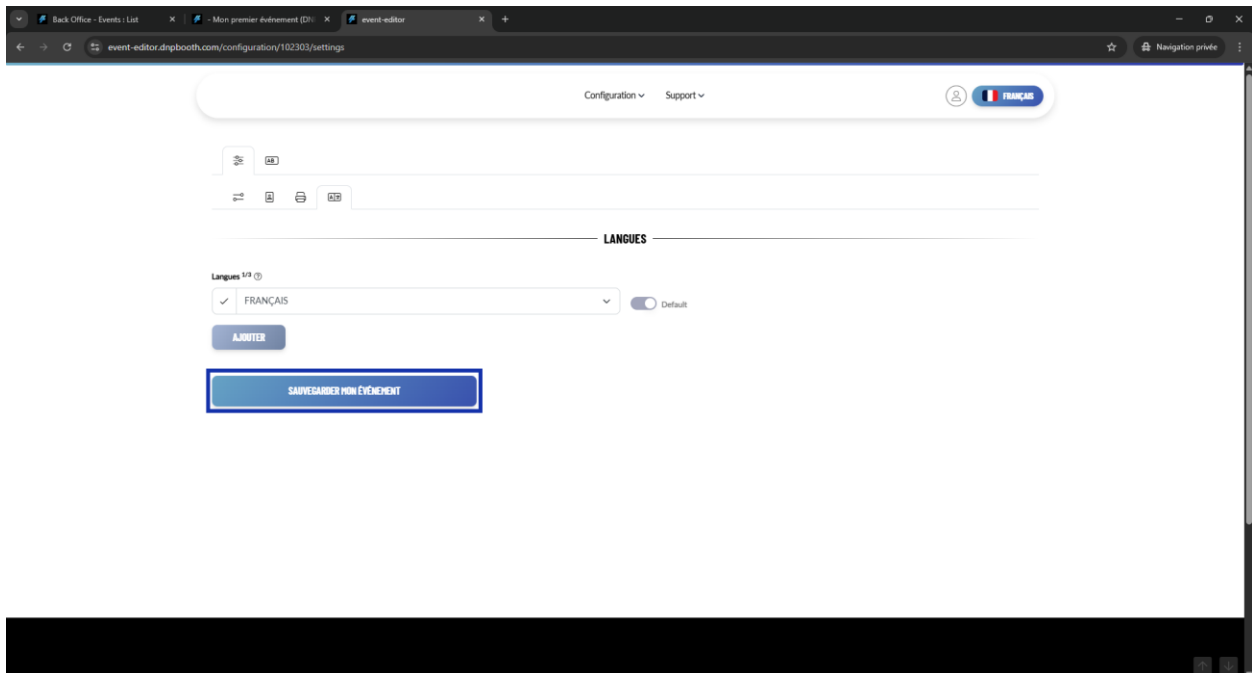

11. Once you've saved your configuration, you can change the settings for sending the photo to the user.

Please note: To send the photo via email, you need to have a PRO license, which means you must have purchased a PRO DATA package beforehand.

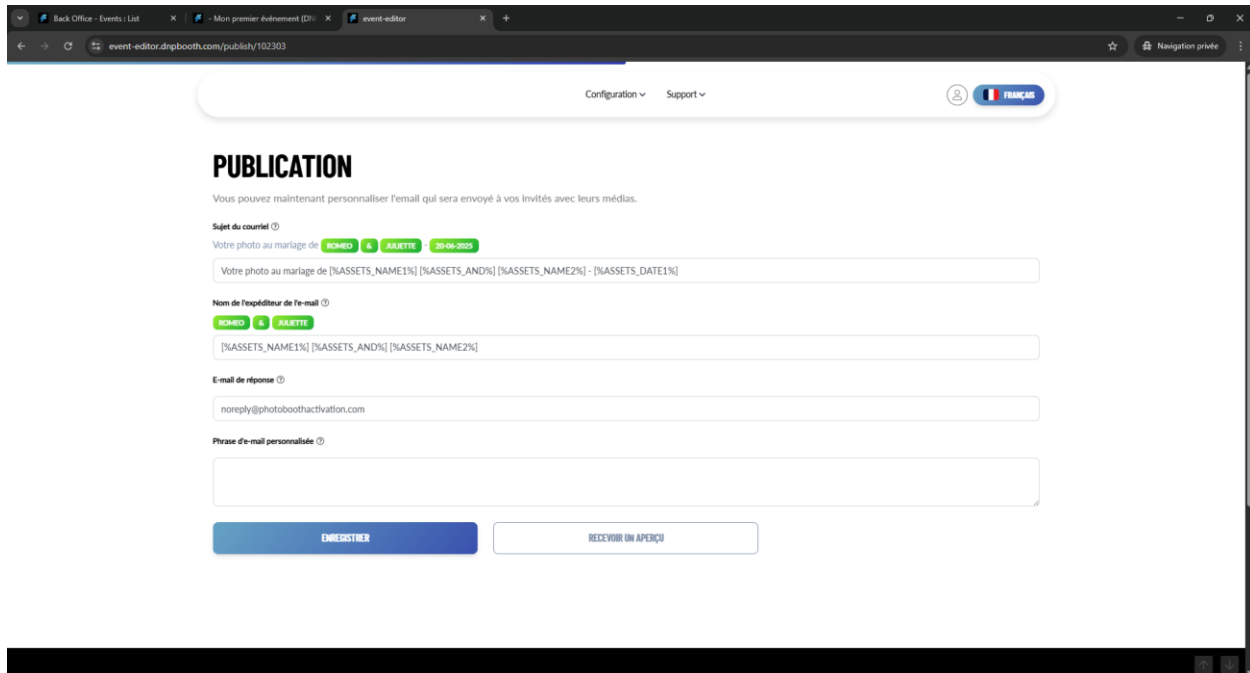

By default, we add the tags you provided in your information. general.

To help you understand:

[%ASSET_NAME1%] = The first name you entered (for weddings, anniversaries, or baby showers)

[%ASSET_NAME2%] = The second name you entered (for weddings only)

[%ASSET_AND%] = The connecting text between the two names (for weddings only)

[%ASSETS_PARTY%] = A message for your group (for group events only)

[%ASSETS_BIRTHDAY1%] = Includes the age and unit you provided (for birthdays only)

You are completely free to remove this information and replace it with whatever you or your client would like.

Click the "Save" button at the bottom of the page to complete your event setup. You'll be taken to the summary tab, where you'll find your event ID, ready to be downloaded to your kiosk.

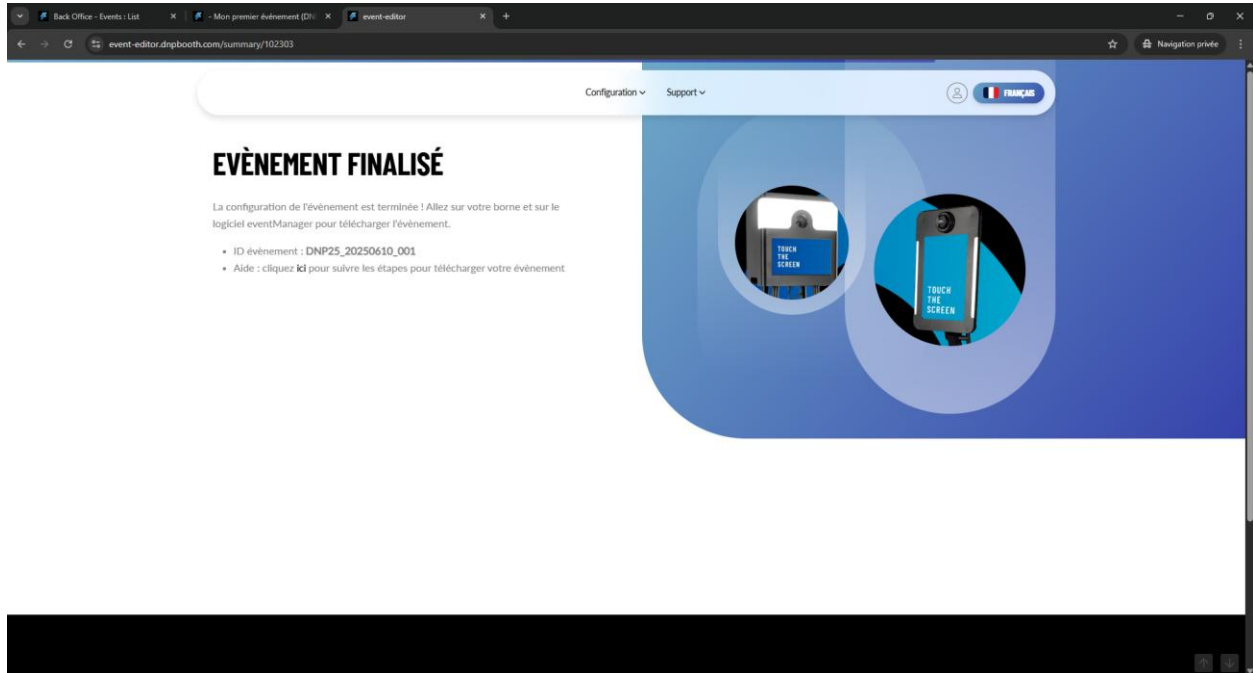

STEP 5: DOWNLOAD AND LAUNCH THE EVENT ON THE PHOTOBOTH

To download and start the event created on the photo booth, go to the booth and double-click on the "Event Manager by Sharingbox" software to launch it if it isn't already running.

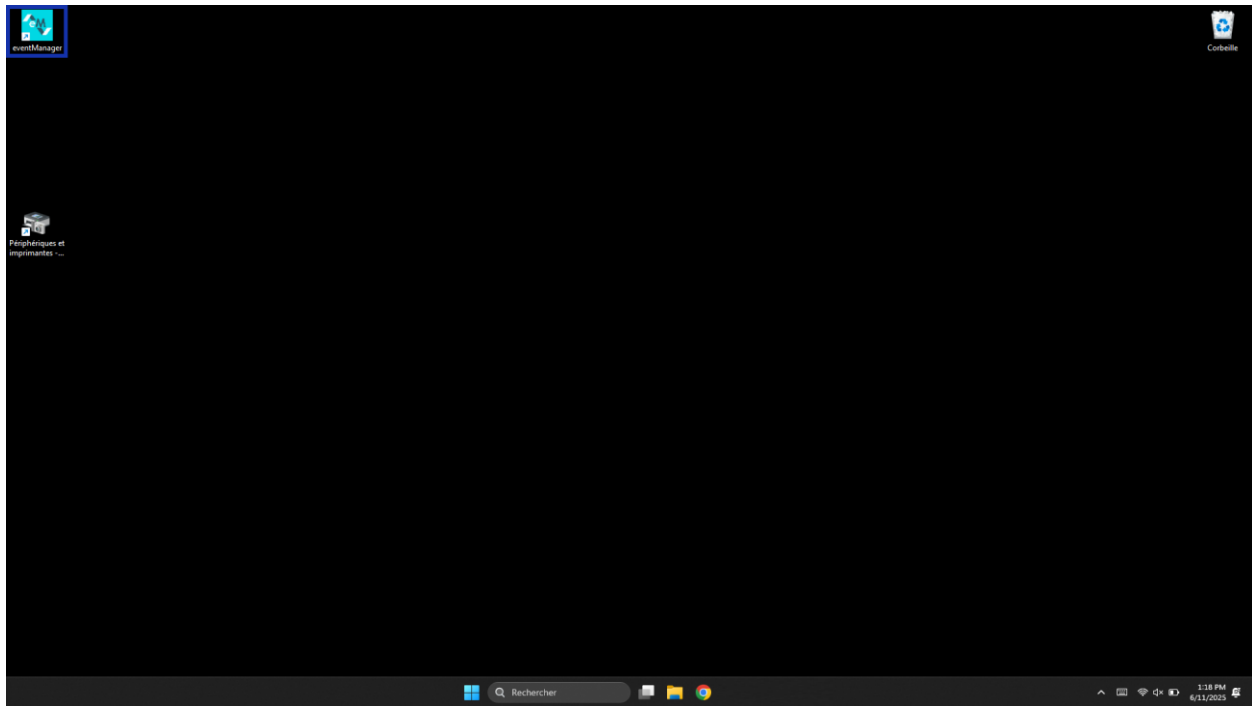

2. Type your access code that was provided to you in the welcome email received earlier.



3. Click the "New" button, select your event ID from the dropdown menus, and then click the "Download" button.

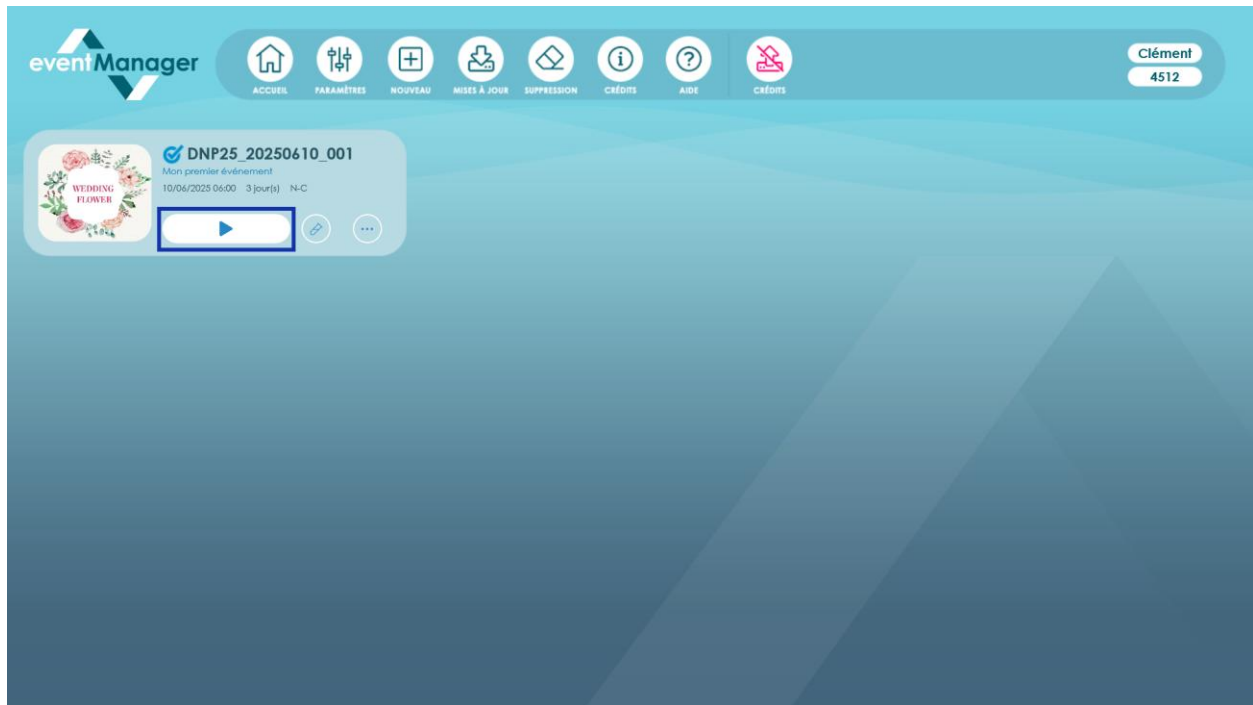

STEP 6: RECOVER THE MEDIA FROM YOUR EVENT

After your event is over, you'll be able to collect all the media captured during it and save them in a folder, either on your device or on a USB drive connected to it.

Double-tap in the top right of the screen to land on the main screen of the eventManager.



2. Type your access code that was provided to you in the welcome email received earlier.



3. On your event, click the button that looks like “...” and in the window that pops up, click the “Export Media” button.



4. Confirm the information window, and then a Windows dialog will appear, allowing you to choose where you want to save all the media captured during your event.

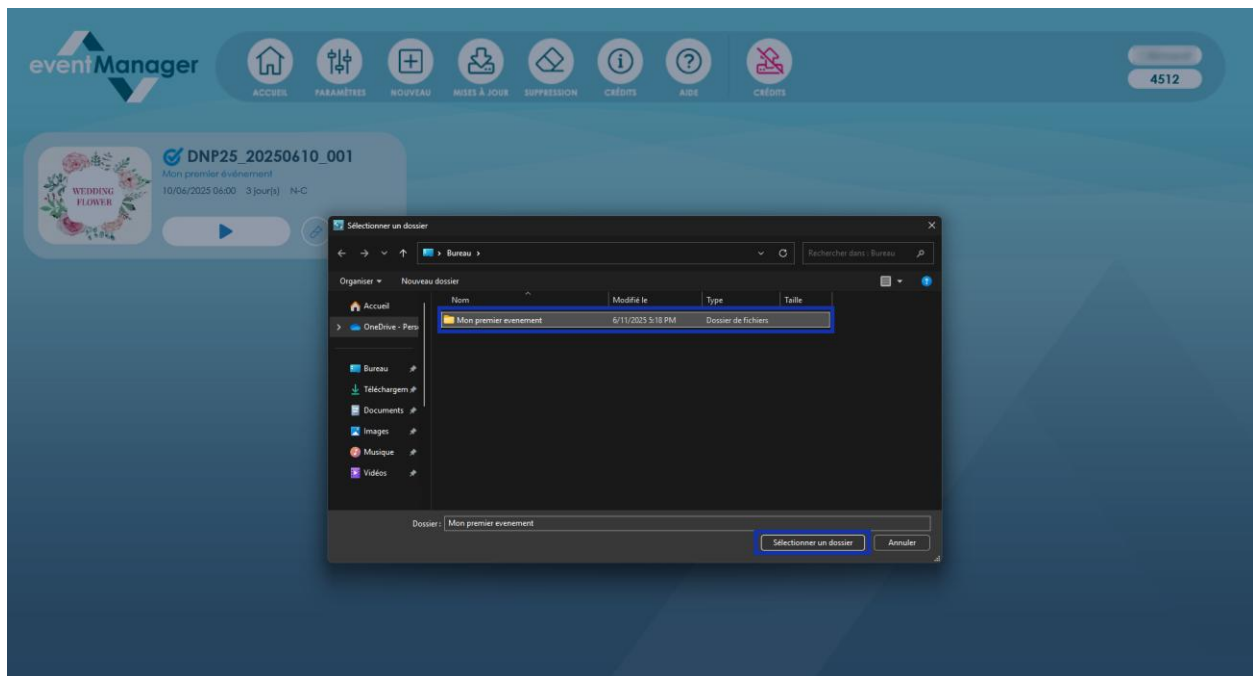
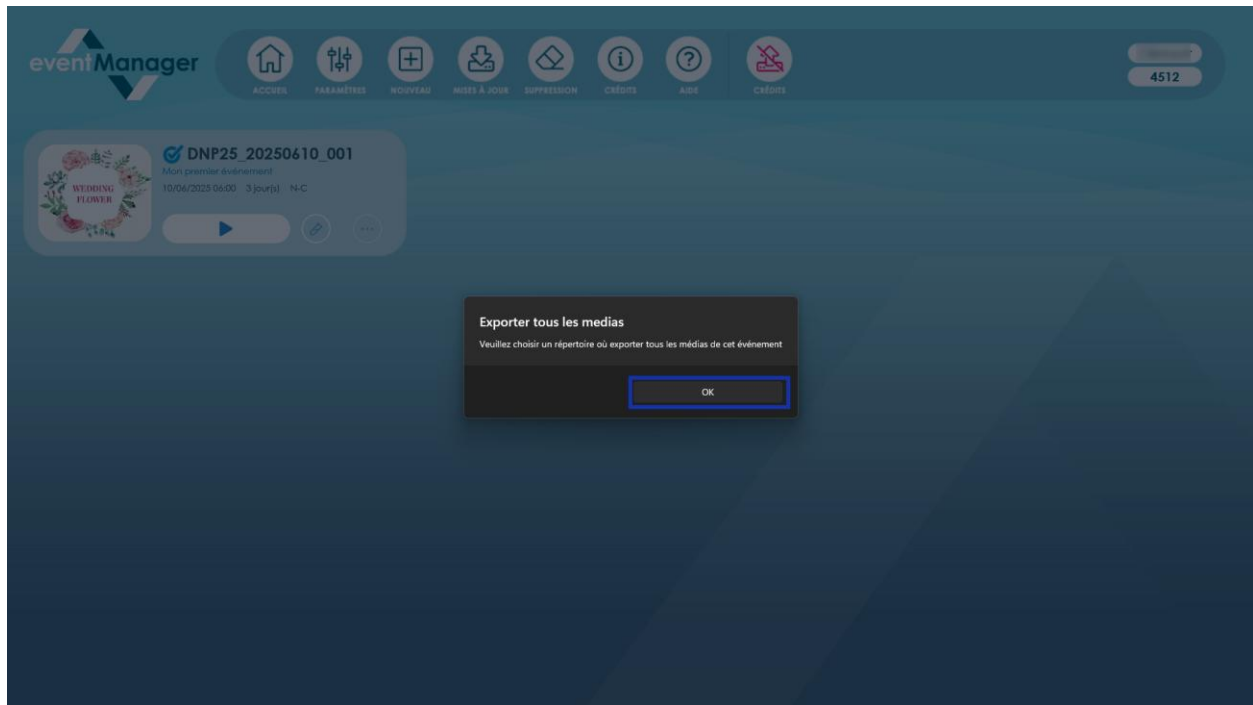

5. You will be notified when the export is complete.

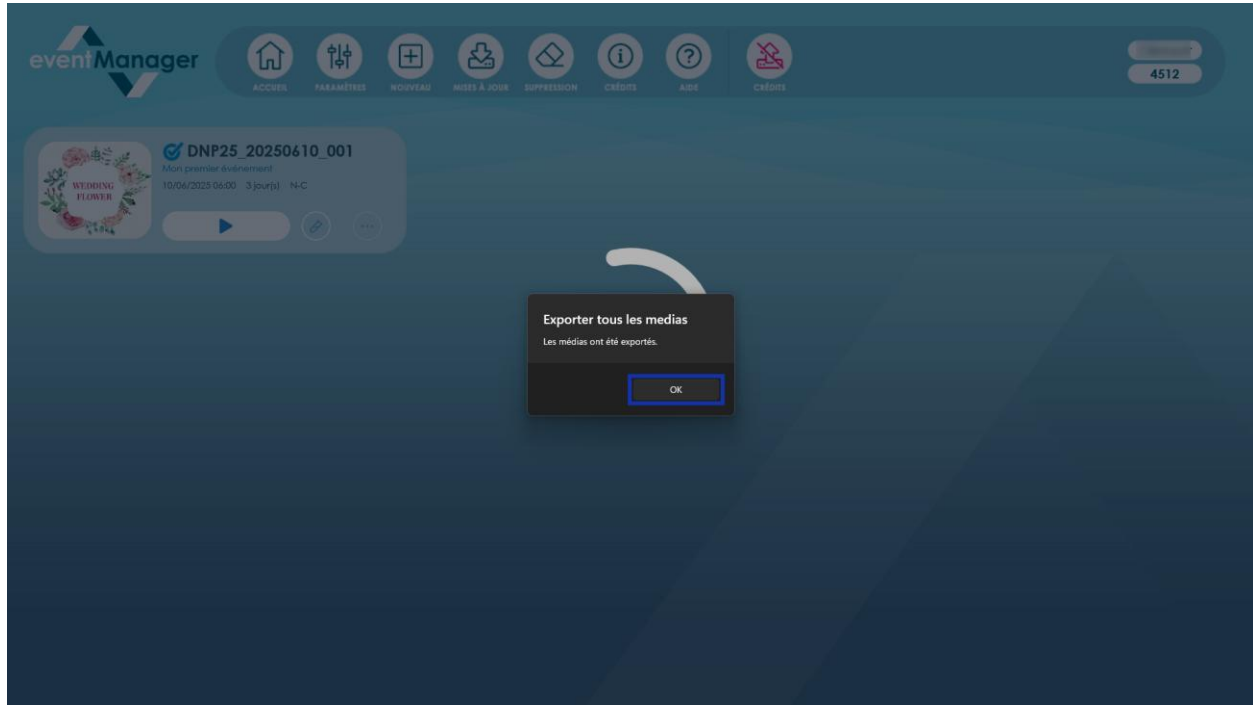

Note: If you have a PRO DATA package assigned to your photobooth and it is connected to the internet, all media will be published and accessible from your event space.

