

DNP Booth
by /sharingbox/

THE **LITE**



www.sharingbox.com/dnpbooth

SUMMARY

STEP 1: HOW TO ASSEMBLE THE PHOTOBOOTH 3

- 1.1) How to assemble the photobooth3
- 1.2) Install the printer in the photo booth.
- 1.3) Turn on the photo booth.
- 1.4) Load the consumables into the DNP DS6209
 - 1.4.1) Loading the ink ribbon
 - 1.4.2) Loading the paper10

STEP 2: CONNECT AND UPDATE 15

- 2.1) First time setup for the photobooth and changing language15
 - 2.1.1) Wi-Fi Connection 17
- 2.2) Windows Updates19
- 2.3) Software updates22

STEP 3: CREATE AN ACCOUNT AND LINK IT TO THE PHOTOBOOTH 26

- 3.1) Create your account26
- 3.2) Log in to your account28

STEP 4: CREATE AND CONFIGURE AN EVENT 32

- 4.1) Create an event32
- 4.2) Configure your event35
 - 4.2.1) Selection of your event type35
 - 4.2.2) Configuration of your "theme" event37

STEP 5: DOWNLOAD AND LAUNCH THE EVENT ON THE PHOTOBOOTH 49

STEP 6: RECOVER THE MEDIA FROM YOUR EVENT 52

STEP 1: HOW TO ASSEMBLE THE PHOTOBOOTH

1.1) How to install the photobooth

1. Open the box and take out all the components from the carrying bags.
2. Turn the plate upside down (holes facing up)



3. Insert the legs into the holes, making sure to place the wired leg in the largest hole. Secure the legs by tightening the screws.

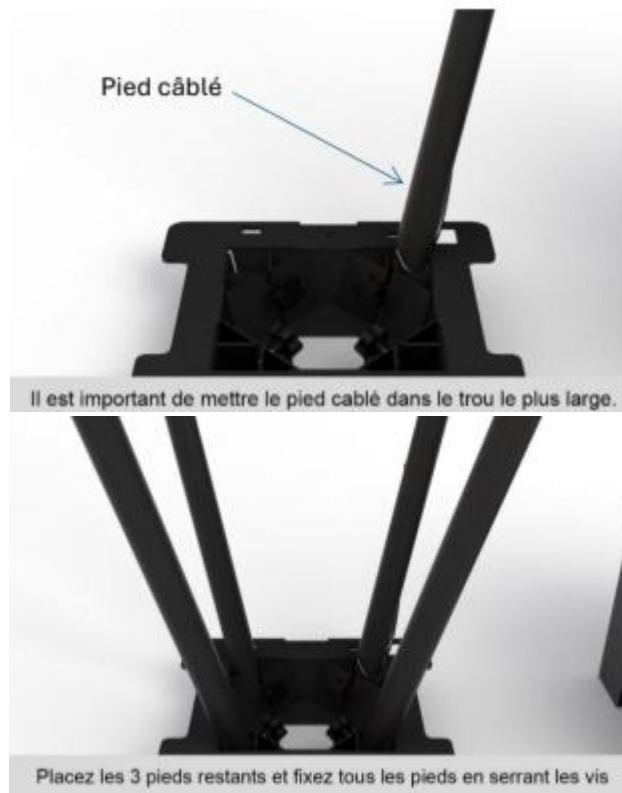

4. Flip the unit over and plug the power cable into an outlet, using an extension cord if needed.



5. Mount the head on the platform.



6. Plug the cable into the head. The photobooth light should turn on.



7. Secure the head using the screws located at the back of the unit. To do this, open the rear cover as shown below.



9. Retrieve the screws, then insert them into the 2 screw holes under the plate.



1.2) Install the printer in the photo booth.

1. Open the printer's hatch on the left side of the device.



2. Remove the removable back cover of the device by sliding your fingers into the designated notches and pulling the cover towards you to unclip it.



3. Slide the printer into the device from the back and push it a bit forward towards the printer's output tray to connect the cables.



4. Plug the power cable into the printer. This cable is already connected to the power strip. Then, connect the USB cable from the printer, which is already plugged into the tablet.



Move the printer to the right inside the device and close the printer cover on the side.

6. Secure the printer tightly with the strap. The tightening loop should always be positioned at the back of the printer.



7. (After turning on the device, see 1.3) Reattach the back cover by sliding your fingers into the designated notches. Align the inserts on the back plate with the springs on the device. Then, push the back plate to securely snap the inserts into the springs.



1.3) Turn on the photo booth

1. Turn on the tablet. Once it's plugged in (the device should be lit up) and the back is open, power on the device by pressing the ON/OFF button located on the top of the tablet, as shown below.

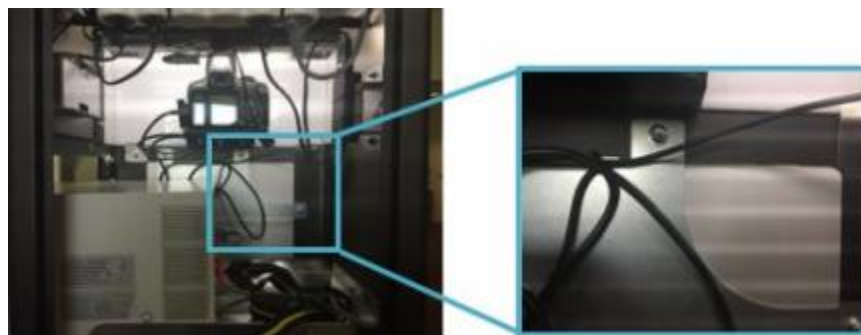

2. Turn on the printer: Open the access panel of the printer and press the ON/OFF button to power it on.



1.4) Load the consumables into the DNP DS620

Open the printer by pulling on the opening lever.

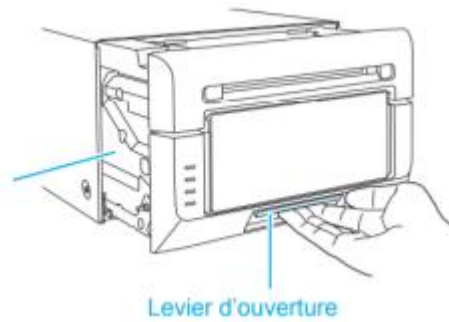

1.4.1) Loading the ink ribbon

1. Remove the ink ribbon holder from the printer and take out the used ink ribbon from the support.



2. Attach the new ribbon to the holder and slightly turn the cylinders to tighten the ribbon.



The ribbon with the yellow tip should be on the "handle" side of the holder. Place the holder with the new ink ribbon back into the printer drawer.



1.4.2) Loading the paper

1. Open the printer and then remove the holder with the ink ribbon.



Press the blue button above to access the paper roll and remove and empty the waste compartment.



3. Turn the paper roll to remove it from the printer, then take out the two black cylinders from the used paper roll.



4. The orange "paper" light will start blinking. Insert the two black cylinders on either side of the new roll of paper and place the roll into the printer with the paper facing down.



5. Roll the paper until you hear two "beeps" from the printer.

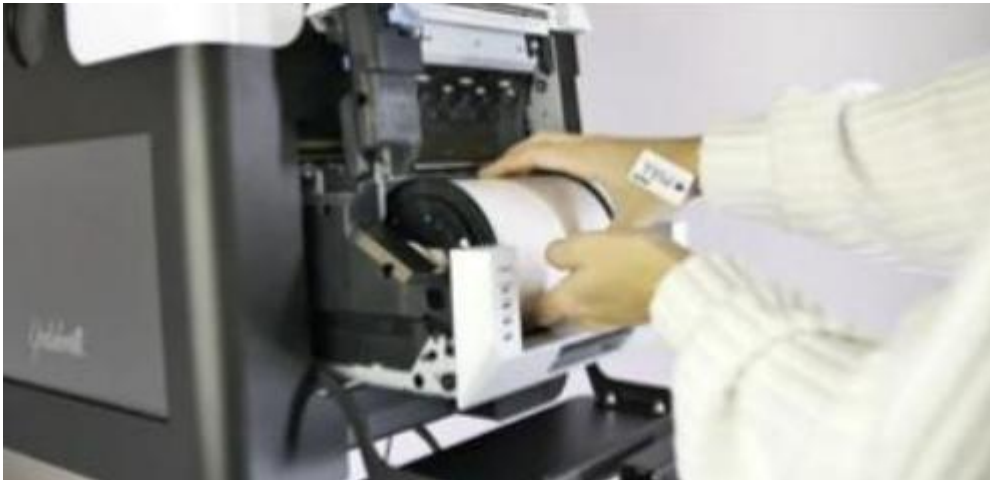

6. Put the waste compartment back and close the drawer after putting the ribbon back in ink pad.



The printer lights will turn green, indicating that it will start cutting 4 to 5 blank sheets to get ready for printing.



NOTE: We recommend always changing the paper and ribbon at the same time.

STEP 2: CONNECT AND UPDATE

2.1) First access to the photobooth and language change

When you receive the device and turn it on for the first time, the eventManager software by Sharingbox will automatically start up. It will be in English.

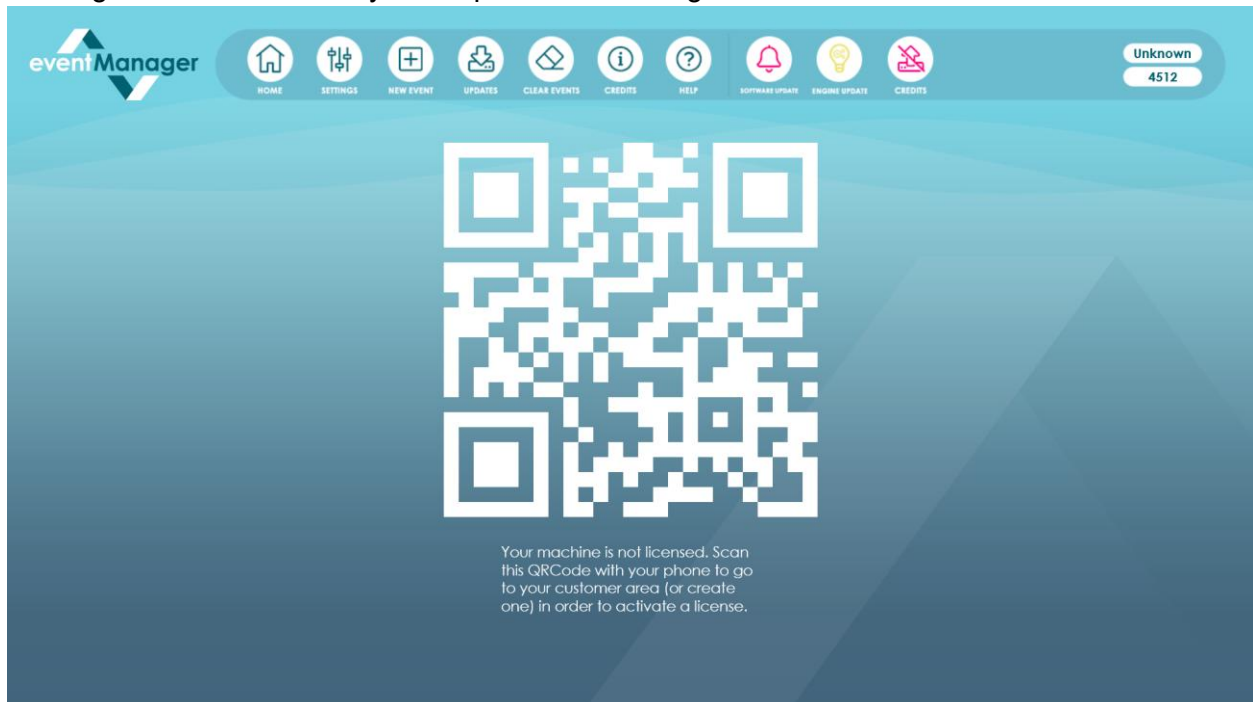

To change the language to French, go to "Settings," then click on the "Languages" button and select "Français."

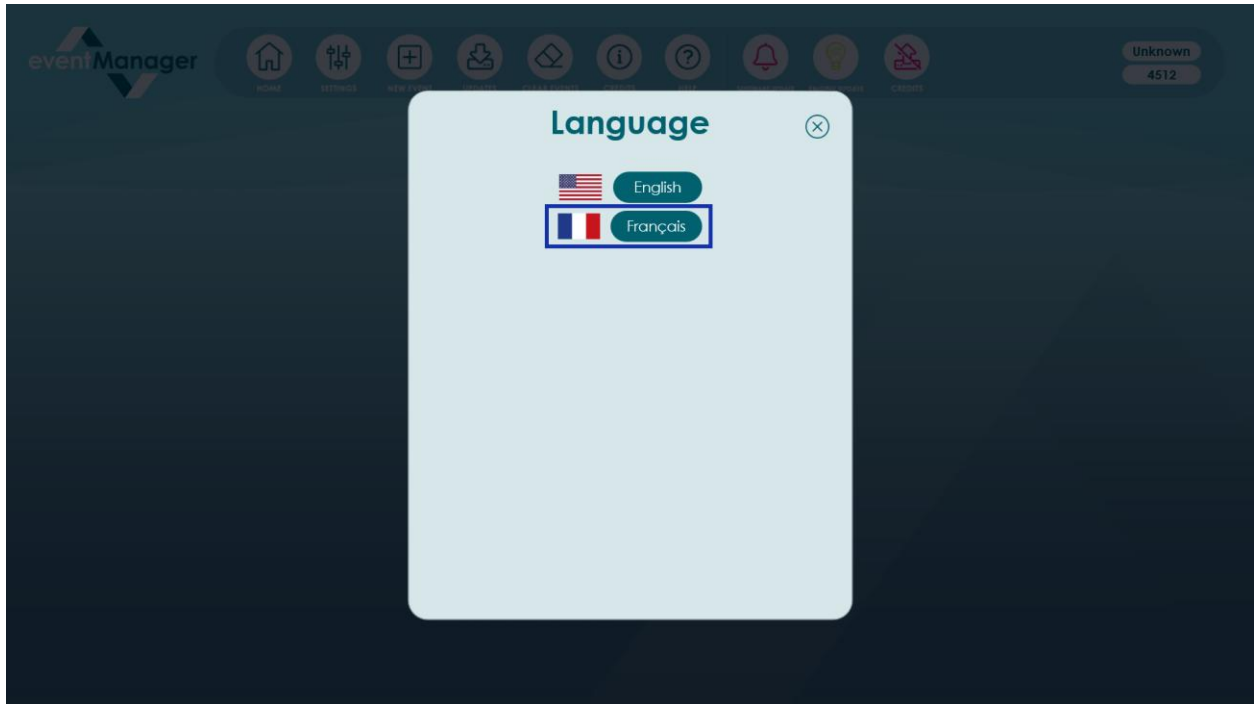
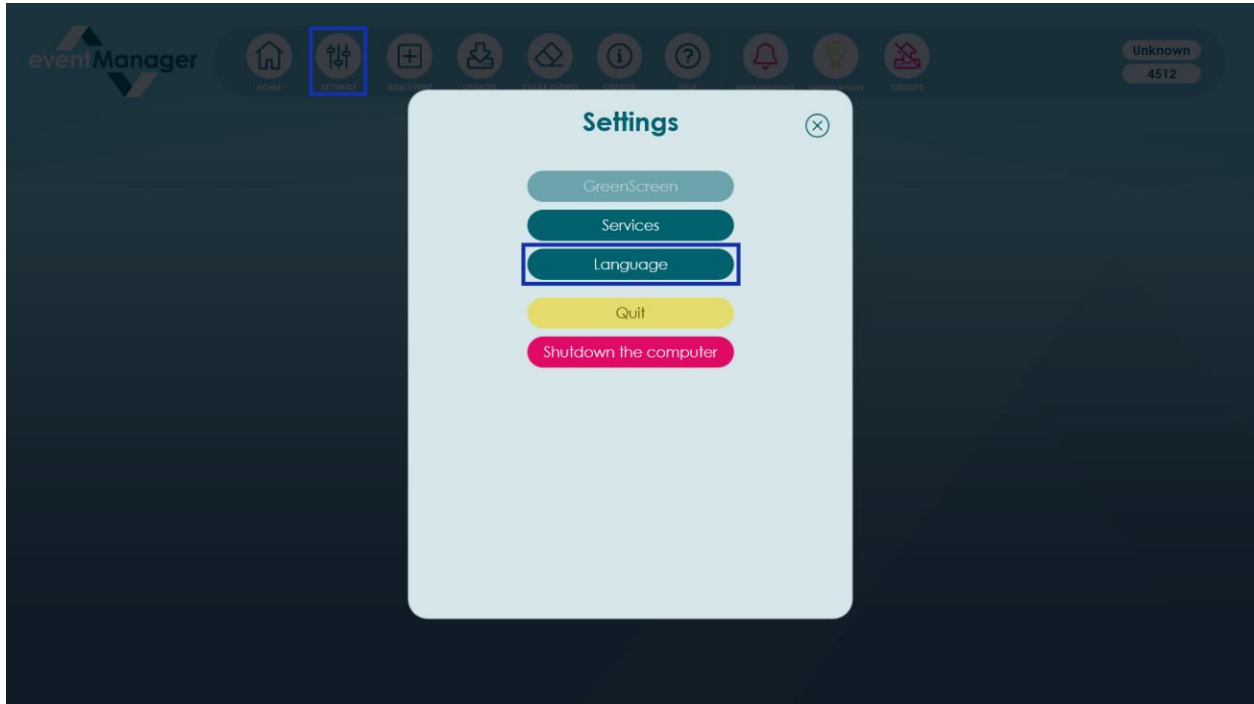

2.2) Wi-Fi Connection

Once the eventManager is *in* French

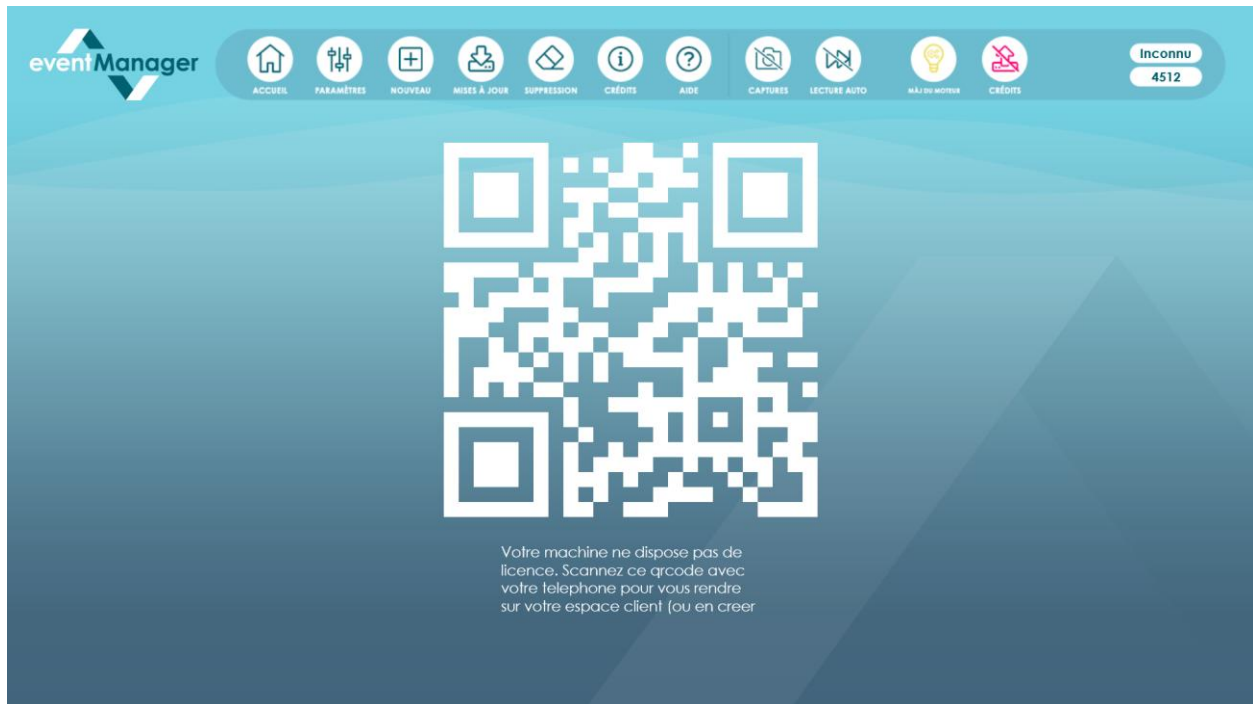

First, connect to your Wi-Fi from Windows. To do this, click on "Settings" in the top menu, and then select "Exit."

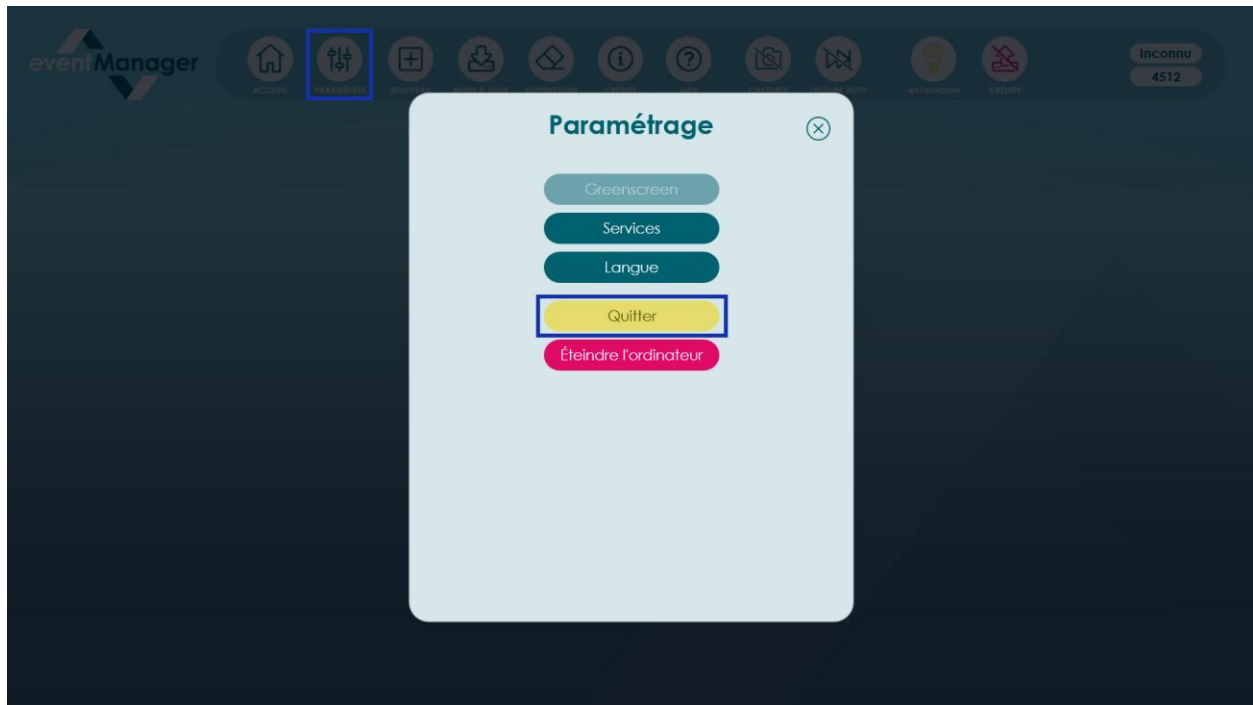

Once you're on your Windows desktop, click on the Wi-Fi icon in the bottom right corner of the screen, and then click the arrow next to the Wi-Fi icon.

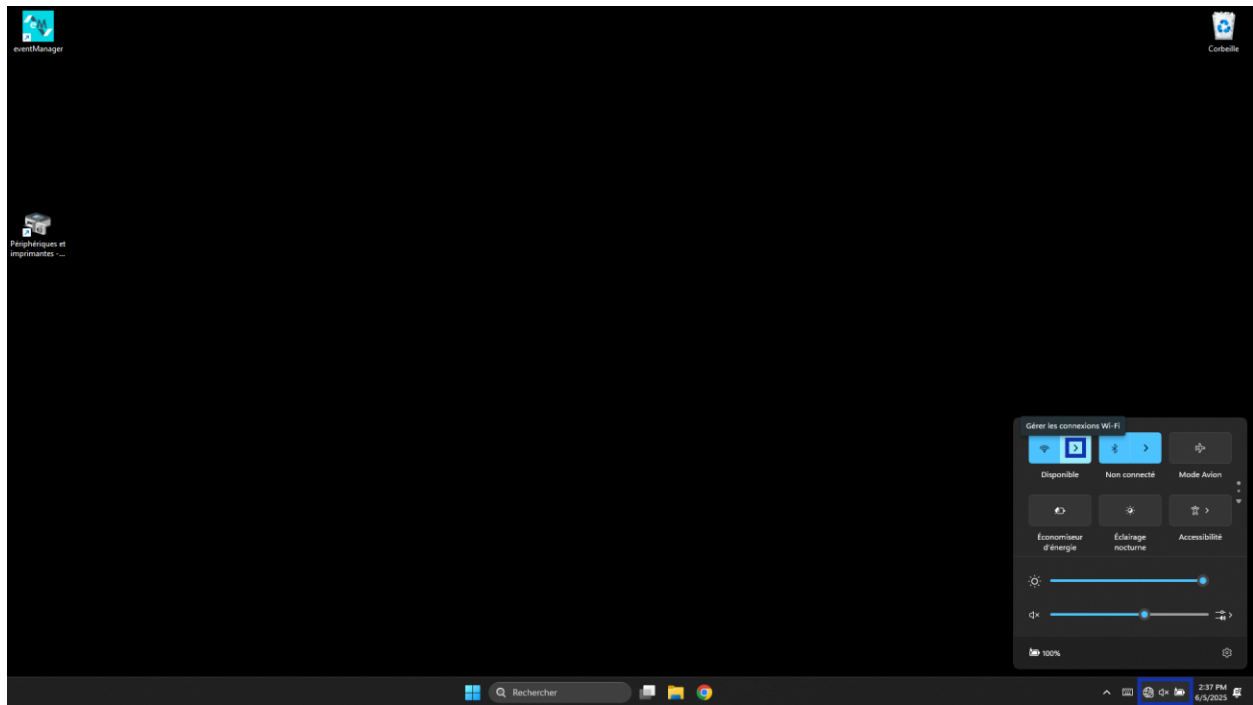

Select your Wi-Fi, enter the password, and connect.

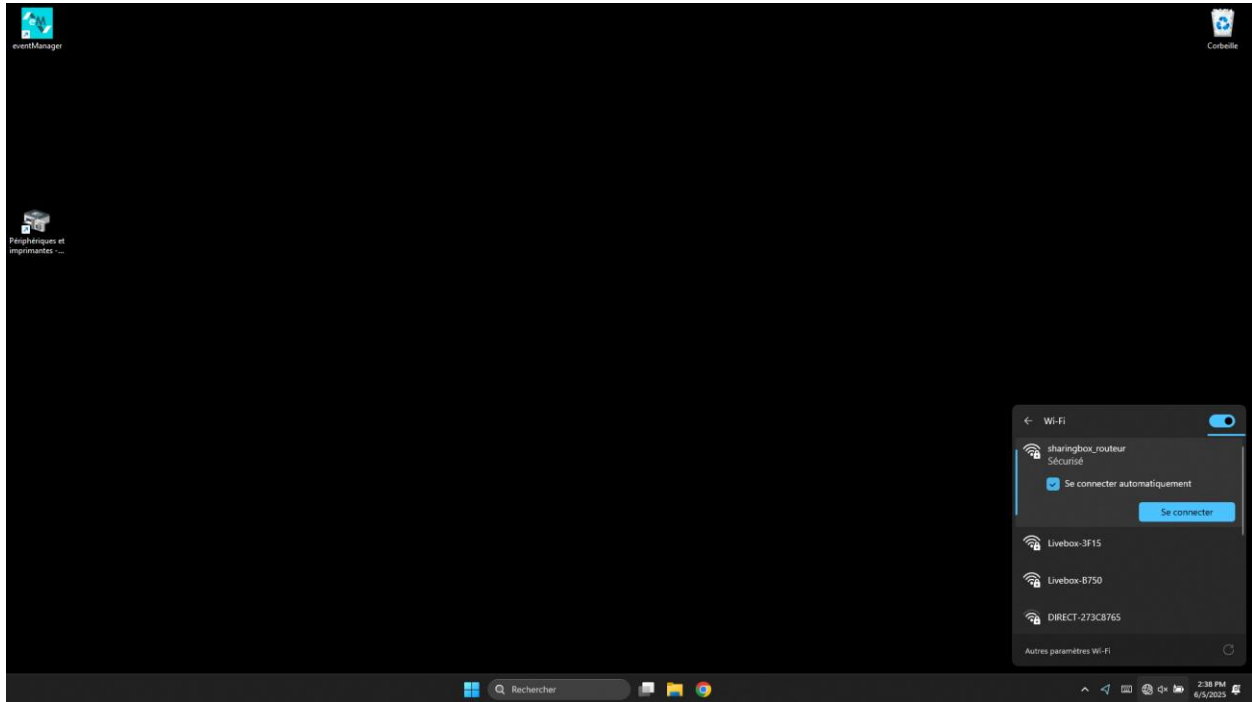

2.2) Windows updates

To make the most of our software, please ensure that your device is up to date beforehand.

Go to your Windows menu and search/click on "Settings"

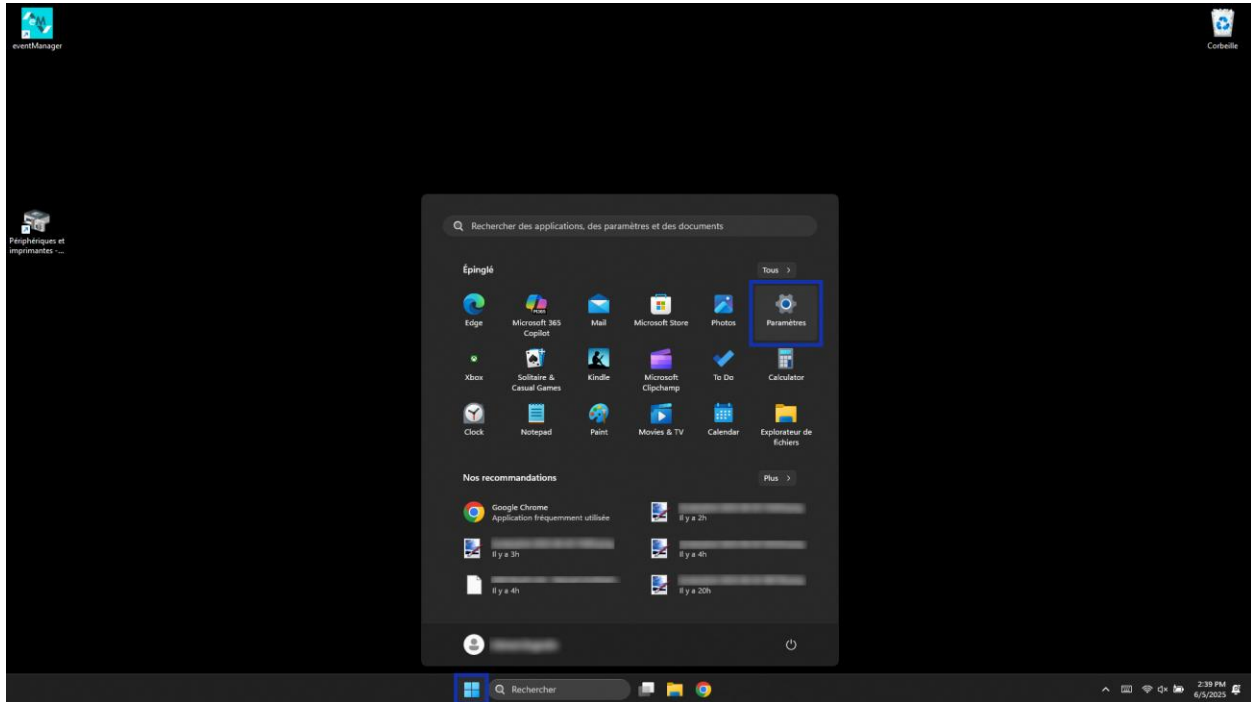

In your Windows settings, go to the "Windows Update" tab and start searching for updates.

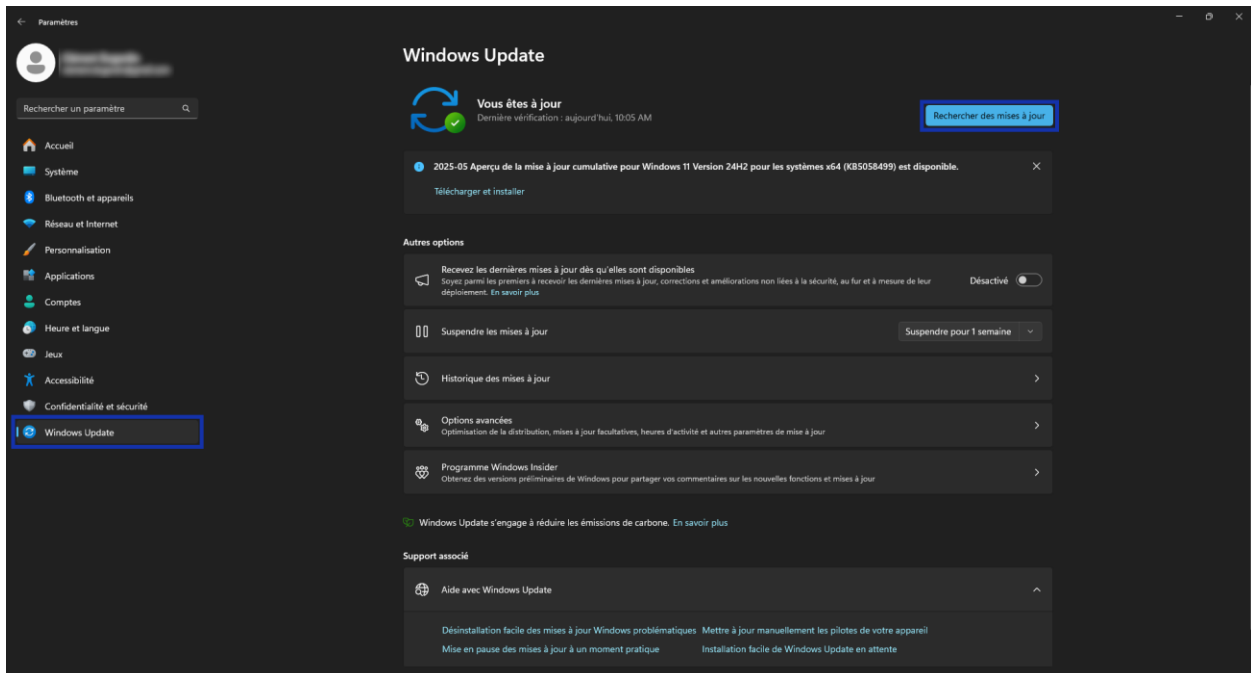

Install all the available updates, and then repeat the process until there are no more updates left.

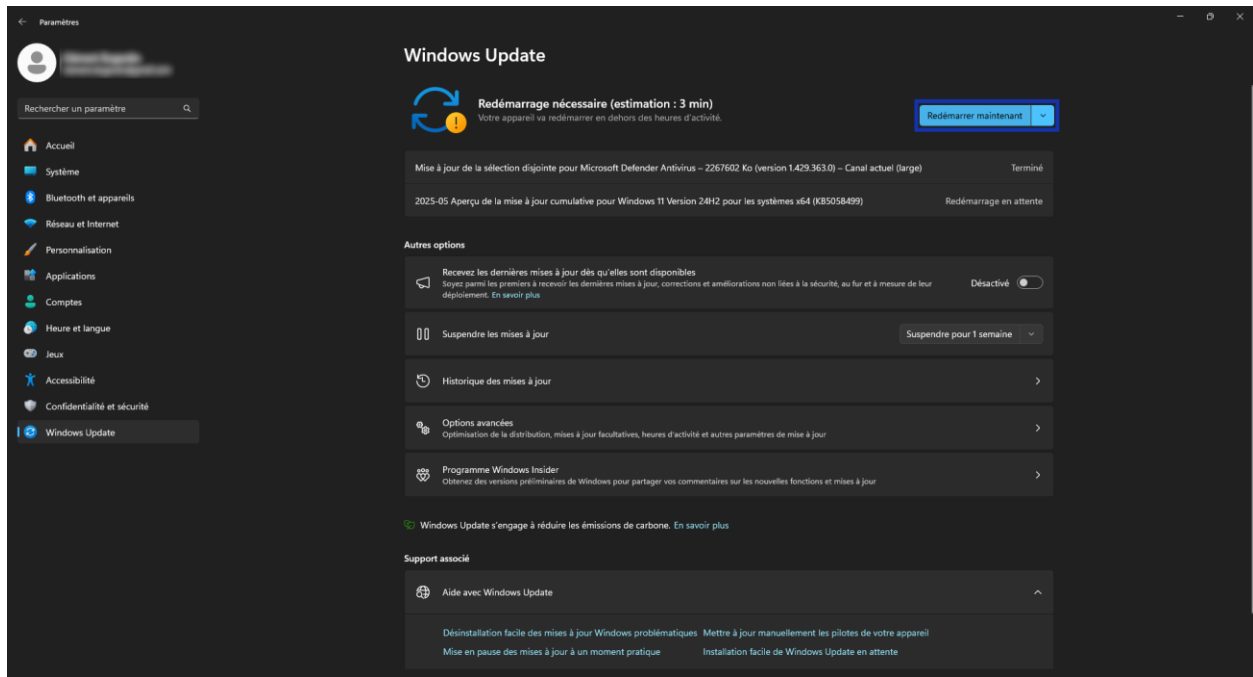

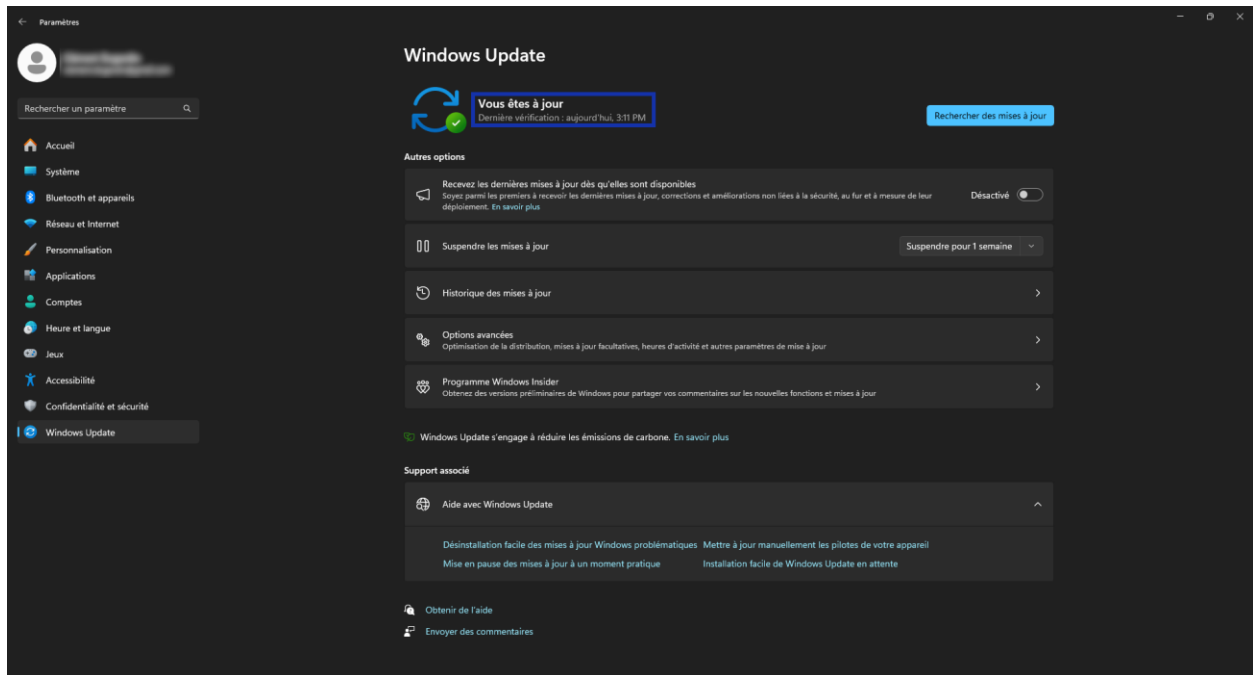

2.3) Software updates

Double-click on the eventManager software shortcut.

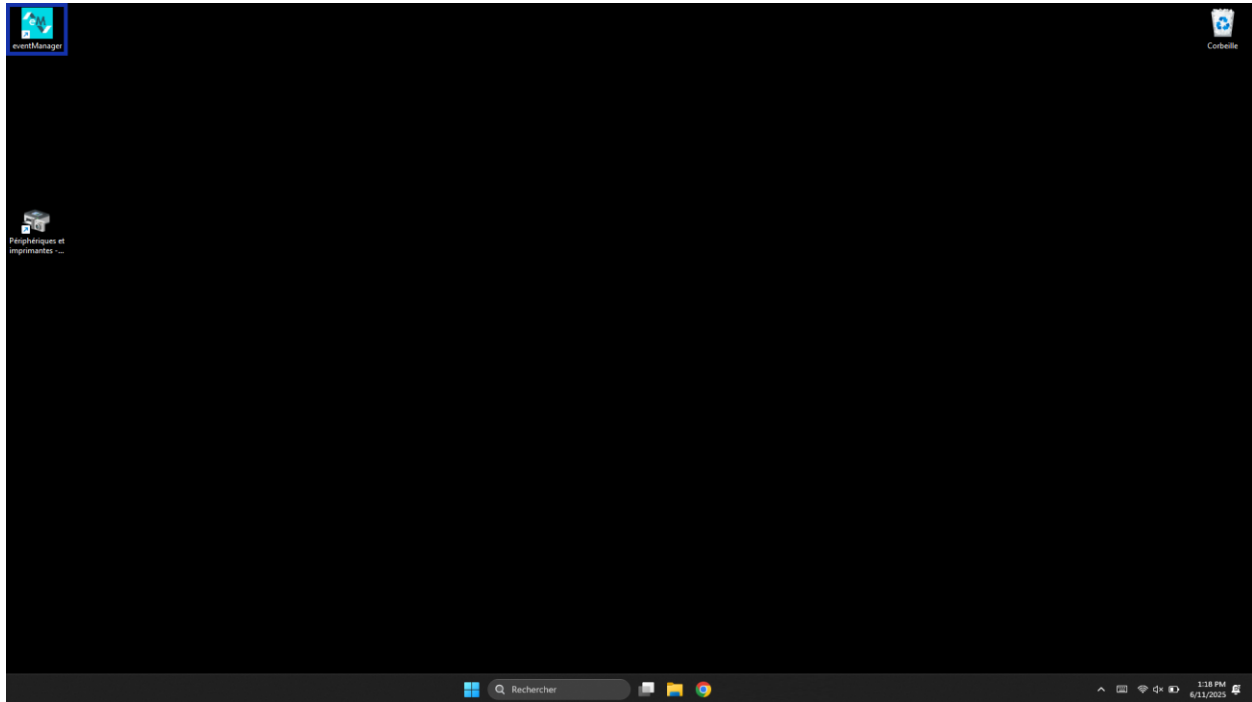

When it starts up, it should automatically open to the administration screen. Check the top right corner to see if the software update icon (the red bell) is available.

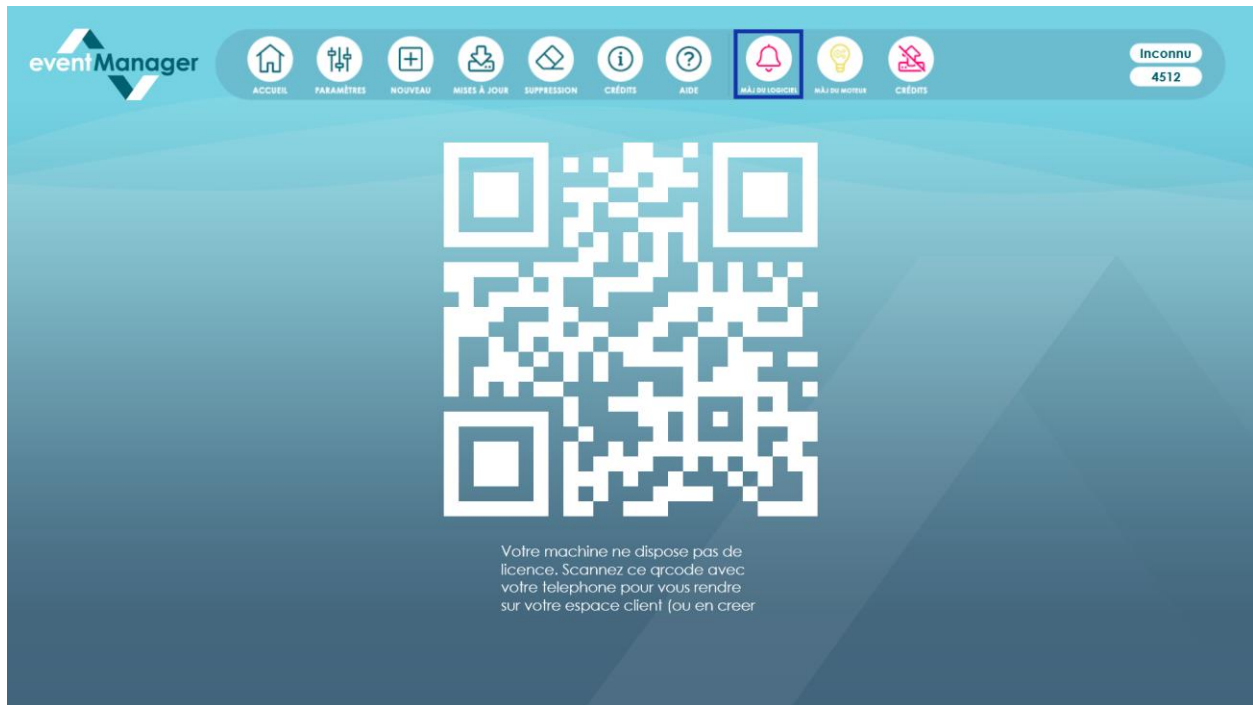

If this is the case, click on it to open the window and start the update procedure.

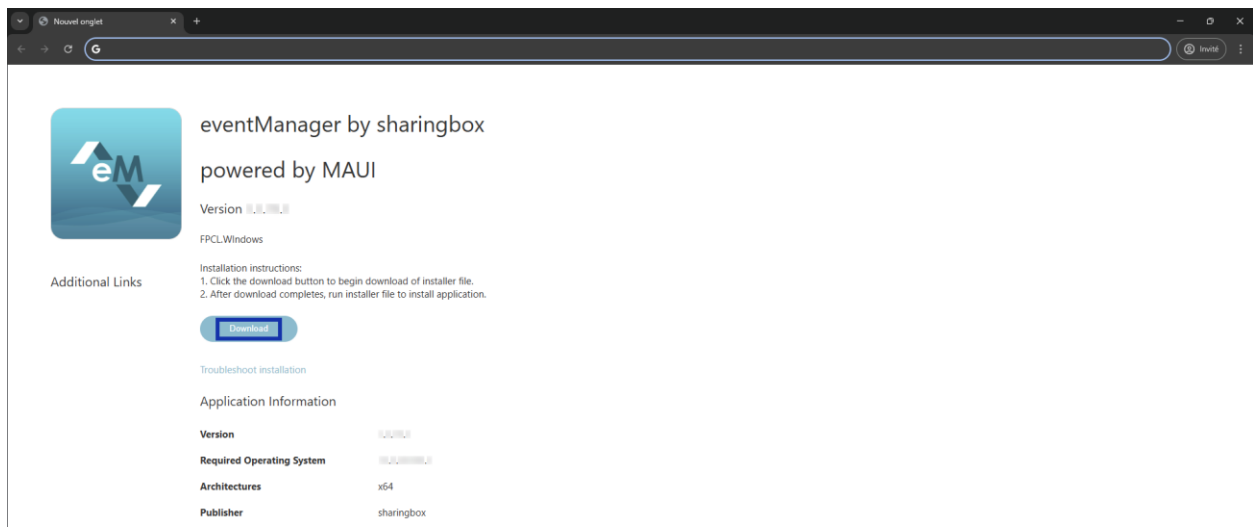
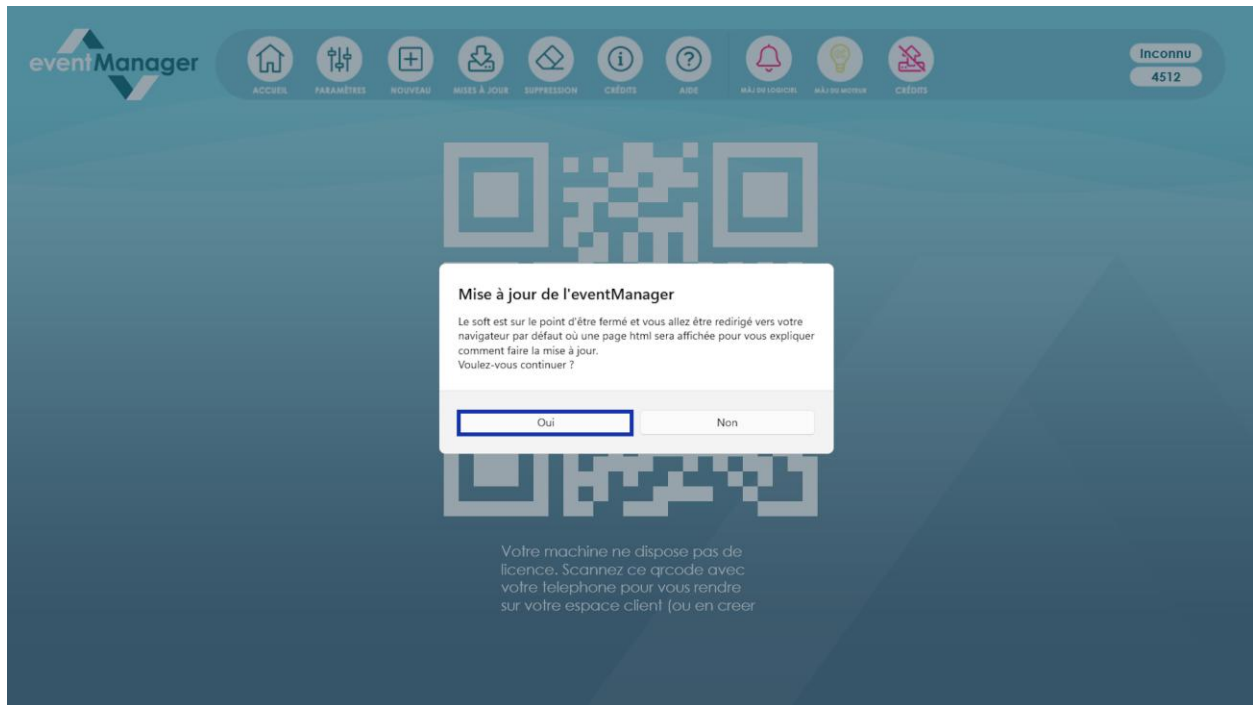

Once you've updated and restarted your software, make sure to update all the software components by clicking the "Updates" button.



STEP 3: CREATE AN ACCOUNT AND LINK IT TO THE PHOTOBOOTH

3.1) Create your account

Now that you're connected to the Wi-Fi, you can start linking the device to an account. To do this, you need to scan the displayed QR code. This will redirect you to a link on your phone where you can create an account that will be linked to the kiosk.



To get started, accept the cookies, click on "Create an account," enter your information, and then click the "Sign Up" button.

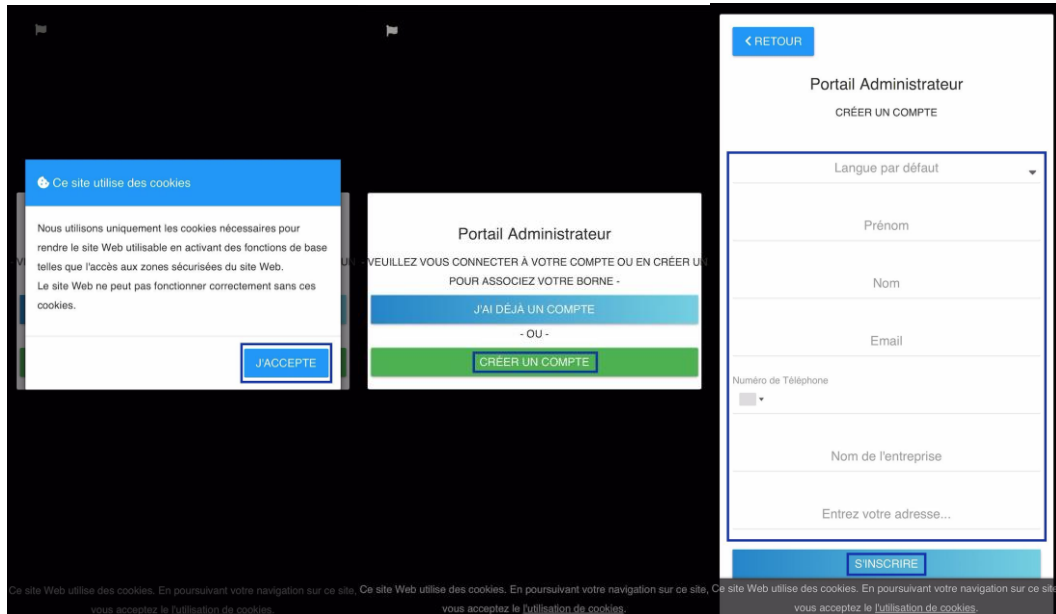

A message will appear after you sign up, letting you know that a welcome email has been sent to your inbox.

Please check your inbox to make sure you received the email. Don't forget to look in your spam or junk folder, just in case.

This contains:

- Here's a link to access the *back office*, which is the main interface for creating events and managing your account.
- Your access code to the eventManager administration panel.
- A link redirecting you to our complete documentation.

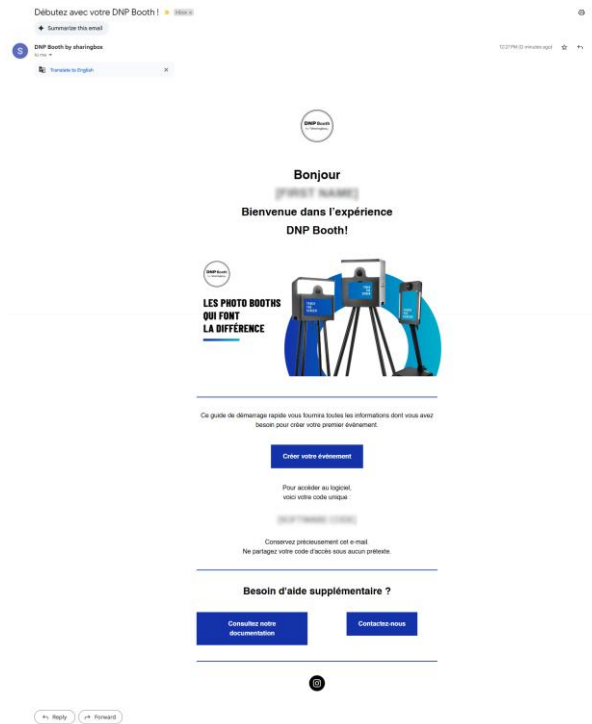

Note: Remember to keep this email.

3.2) Log in to your account

We recommend that you use your own computer for this part up to step 5.

Please go to the back office using this web address: <https://bo.dnpbooth.com/login> ([you can find the link in](#) the welcome email you received).

Please accept the cookies necessary for using the interface.

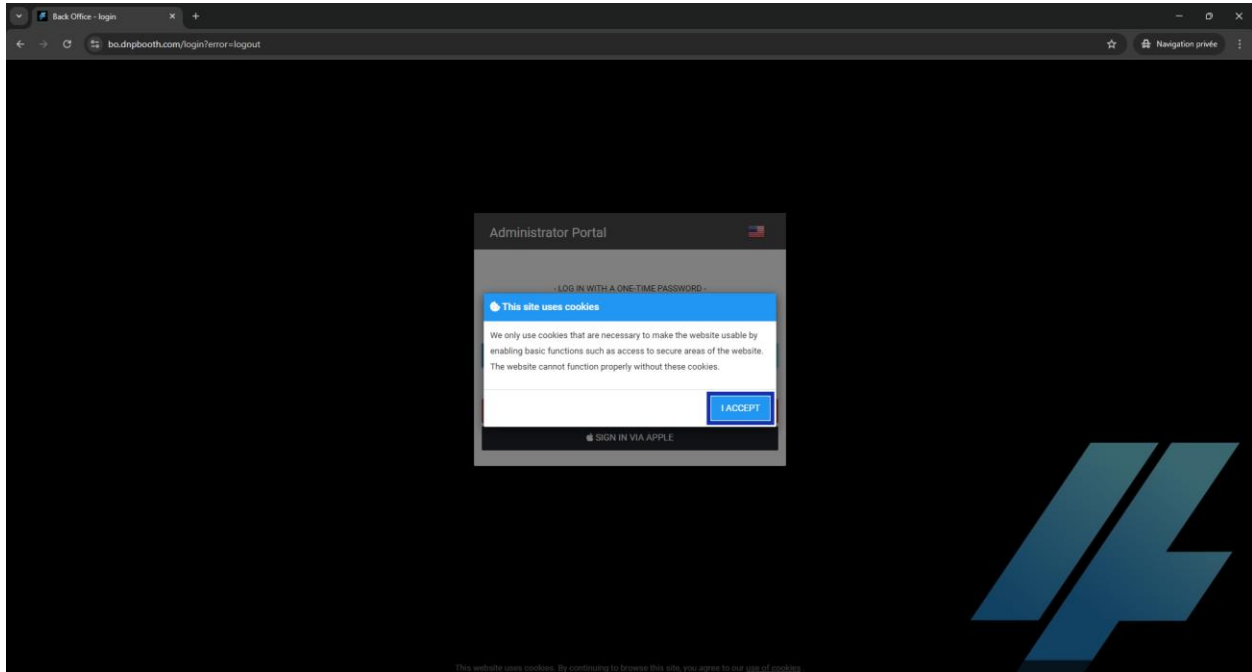

Then log in:

- You can log in using the buttons based on whether your email address is linked to a Google account (Gmail) or an Apple account (iCloud).
- You will receive a one-time password via email, so please remember to check your spam or junk folder as well.

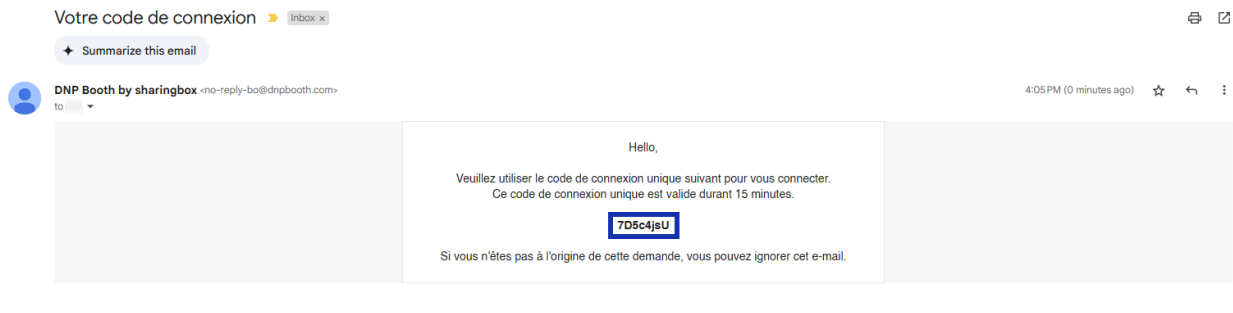
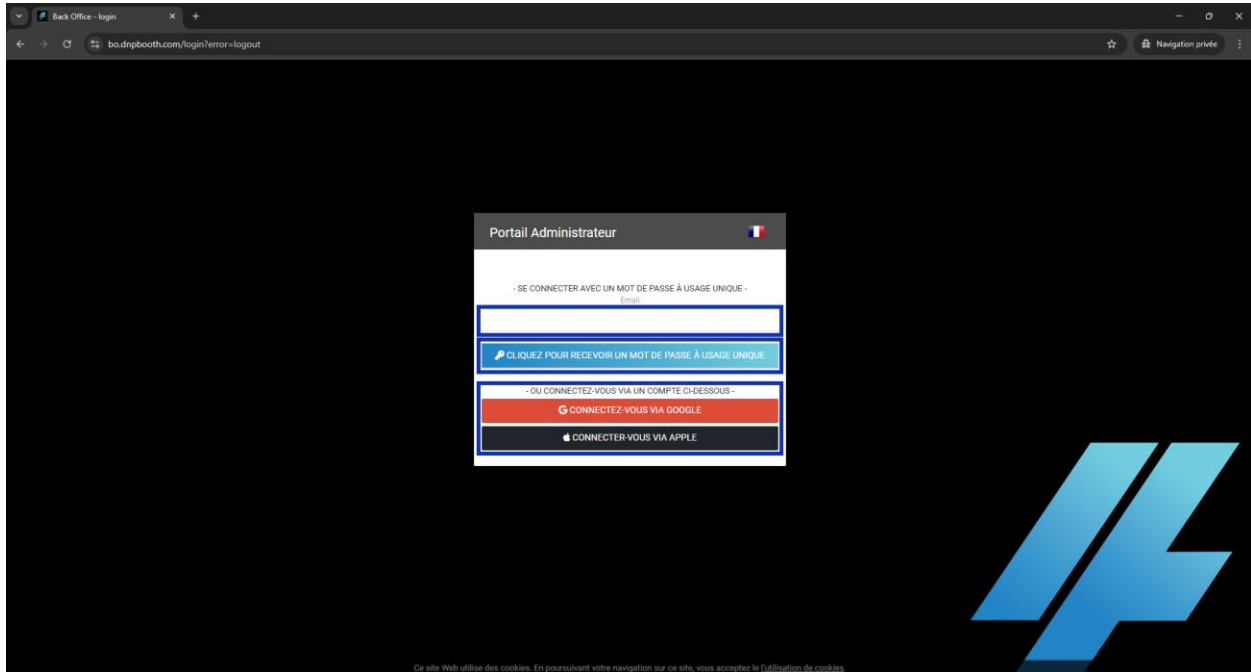

You are now logged into the back office and have a BASIC license by default, which will allow you to create simple events.

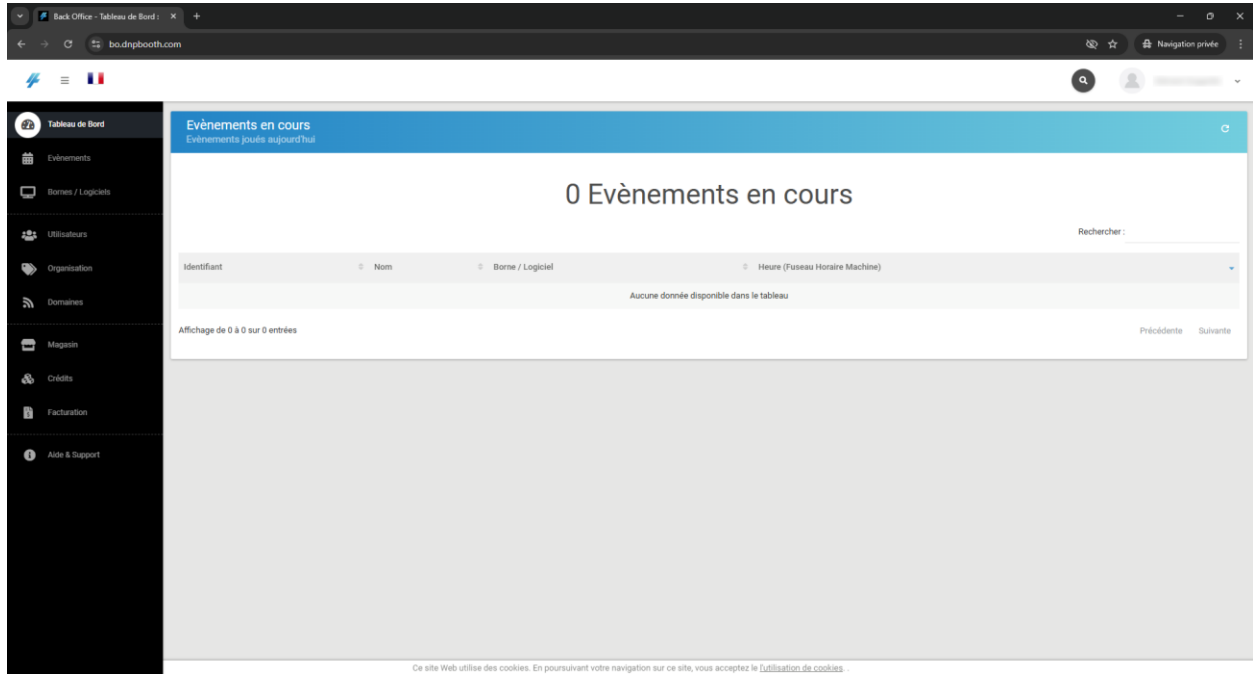

STEP 4: CREATE AND CONFIGURE AN EVENT

4.1) Create an event

NOTE: To create an event, you must be logged into the back office.

Go to the "Events" menu and click on "New" to open the event creation page.

2. Enter the details of your event, including its name, start date and time, and end date and time, then click the "Create" button.

The screenshot displays the 'Nouveau' (New) event creation page in a web browser. The page title is 'Nouveau' and the subtitle is 'Créer un nouvel événement'. The form contains the following fields:

- Organisation: DNP25 (MonEntreprise)
- Nom: Mon premier événement
- Début: 2025-06-10 06:00
- Fin: 2025-06-13 23:59

Below the form, there is a green checkmark and the text: 'RGPD : Conformité avec le règlement général de la protection des données <https://www.eugdpr.org/the-regulation.html>'. A green 'CRÉER' button is located at the bottom right of the form area. The left sidebar shows the 'Evénements' menu with 'Nouveau' selected.

With each event creation, the following is created:

- An event identifier (*event ID*)
- An event space dedicated (*interface event-space*)
- A dedicated configuration space (*event-editor interface*)

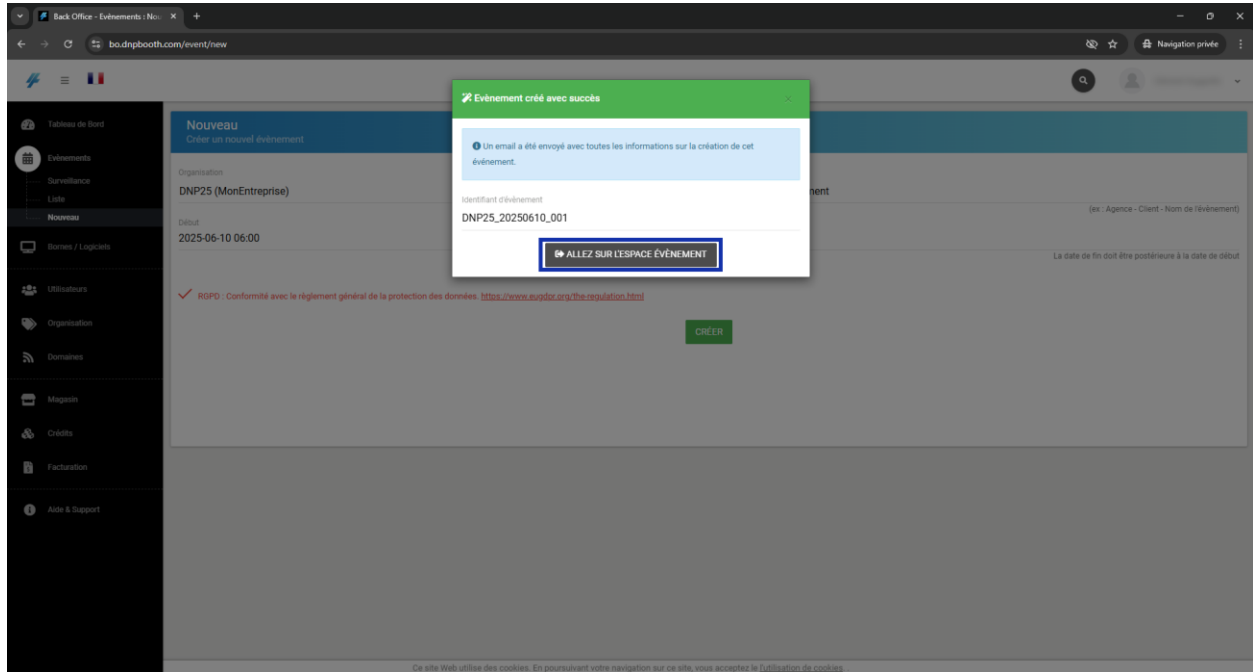

The identifier of your event is made up of 3 parts:

- Your license identifier
- The start date of your event
- An incremental number to identify your event.



You will receive a confirmation email after the event is created, which will include the event *ID*, as well as the start and end times of the event.

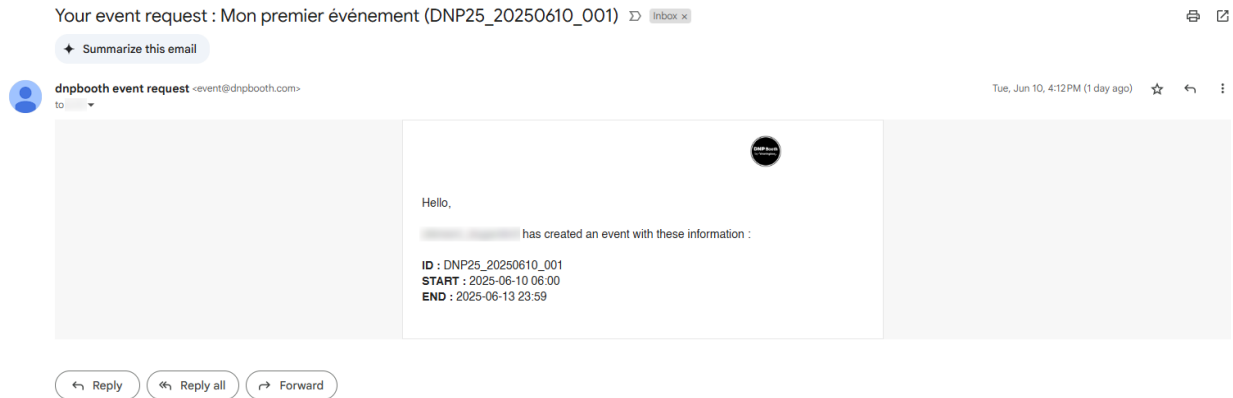

4. You must then go to your event space. For this, there are 2 methods:

- Either directly via the button displayed after creating your event.

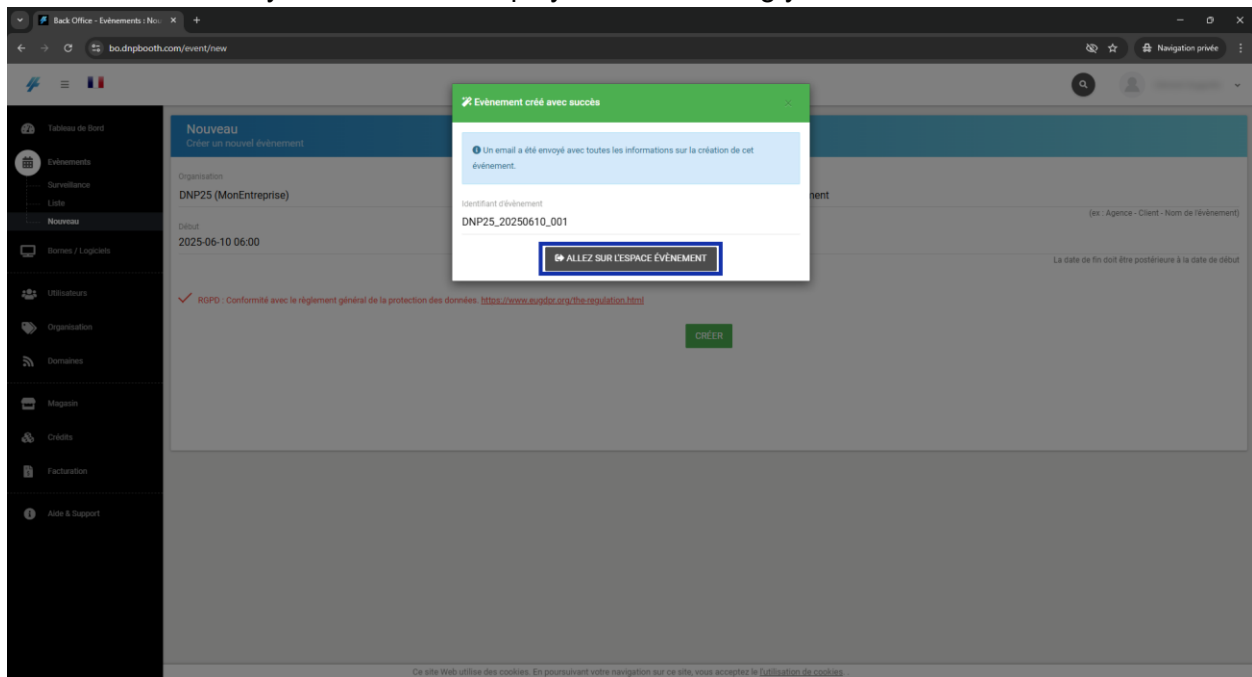

- In the back office, go to the "Events" menu, click on "List," find your event, and then click on the icon to the left of its ID.

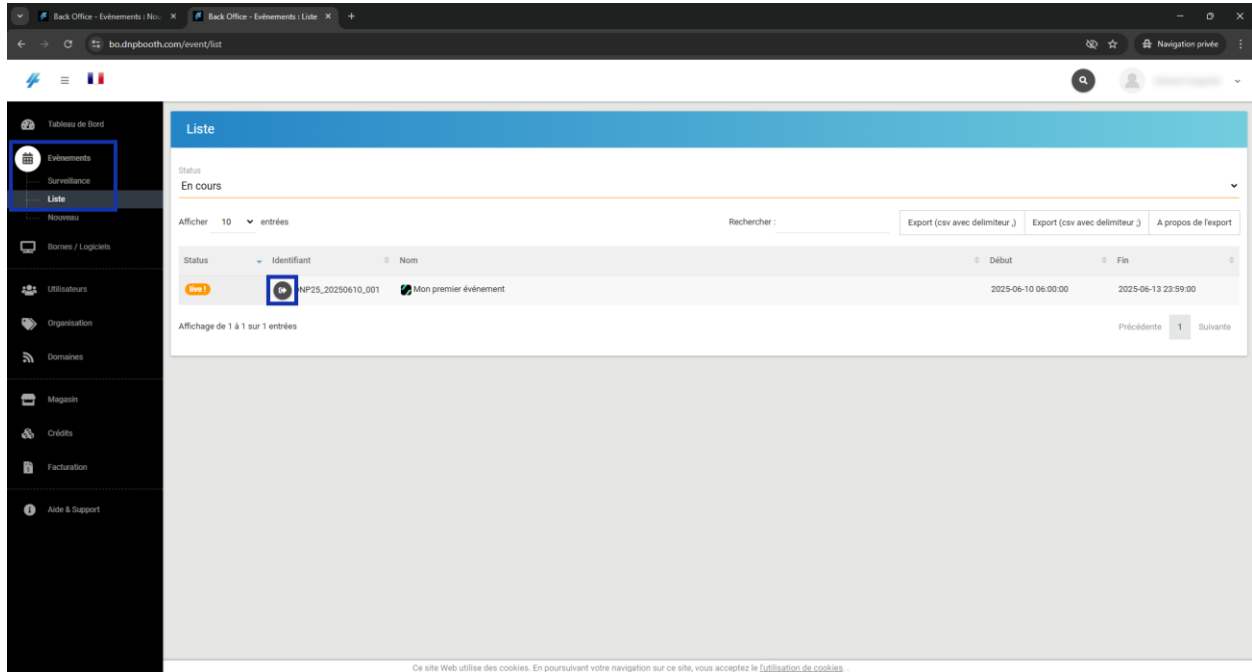

Note: For the second method, if you can't find your event right away, make sure to use the correct filter in the "Status" section at the top of the page.

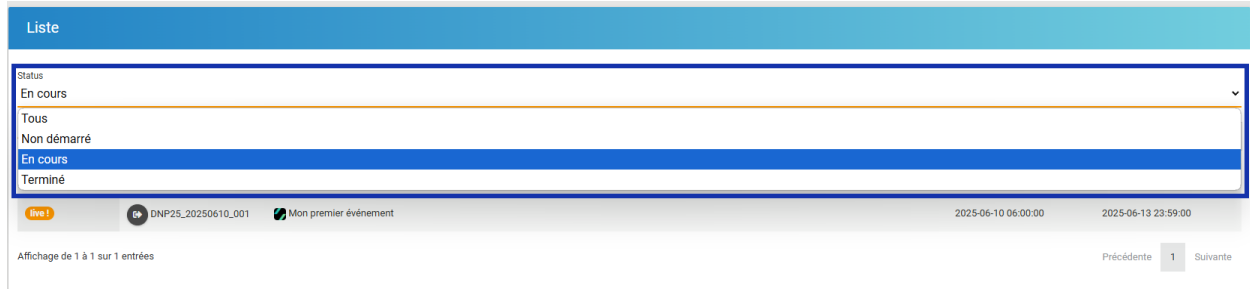

4.2) Configure your event

4.2.1) Selection of your event type

Once you access your event space, click on the "Configuration" tab on the left side of the screen, and then click the "Open Configuration Editor" button. This will take you to the event editor interface specifically for your event.

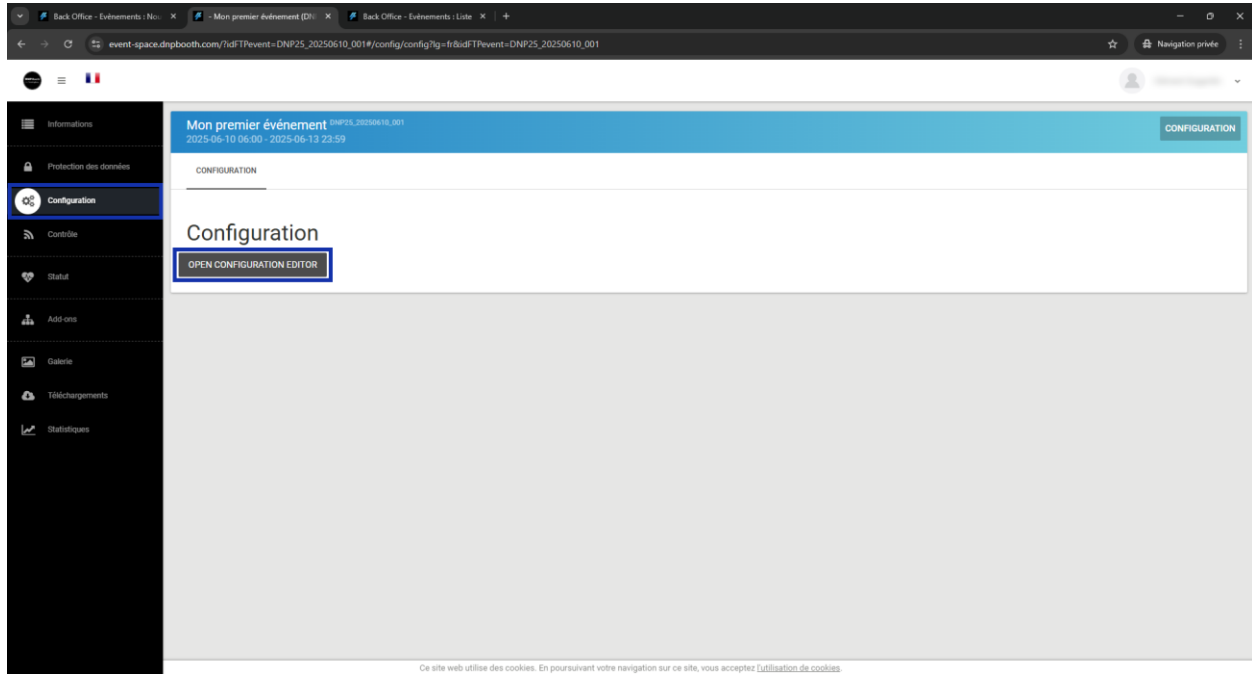

Click the "Set Up My Event" button to get started and explore the available setup options.

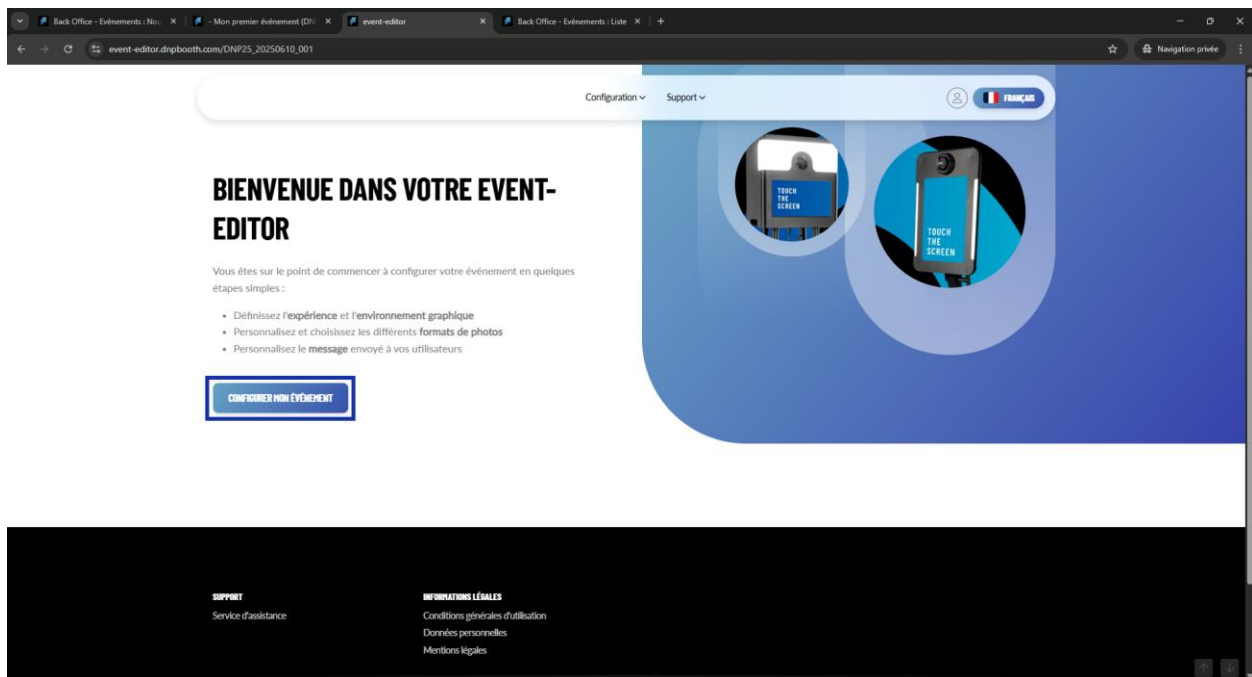

When you set up your event for the first time, you'll have the option to choose between two types of events:

- **Themes:**
For private events, you can choose from the private catalog and only enter specific details based on the type of event you select.
- **TEMPLATES:**
Commonly used for corporate events, you can choose a standard event template here and customize the design and specific configuration options based on the selected preset.

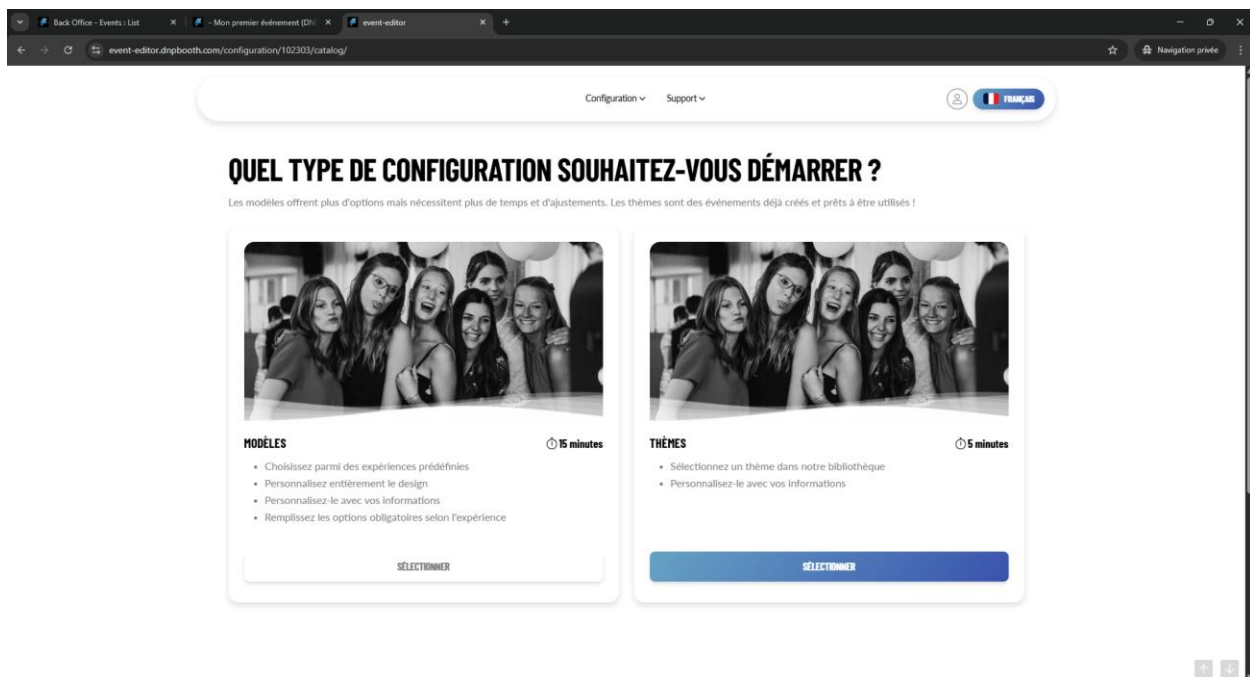

Now, we will explain how to set up a sample wedding event based on a theme.

Note: To learn how to set up an event based on a template, please refer to our more detailed documentation at <https://www.dnpphoto.eu/fr/telechargements/manuels-brochures/manuals/dnp-booth-1>.

4.2.2) Configuration of your "theme" event

1. Click on the "Select" button in the themes area.

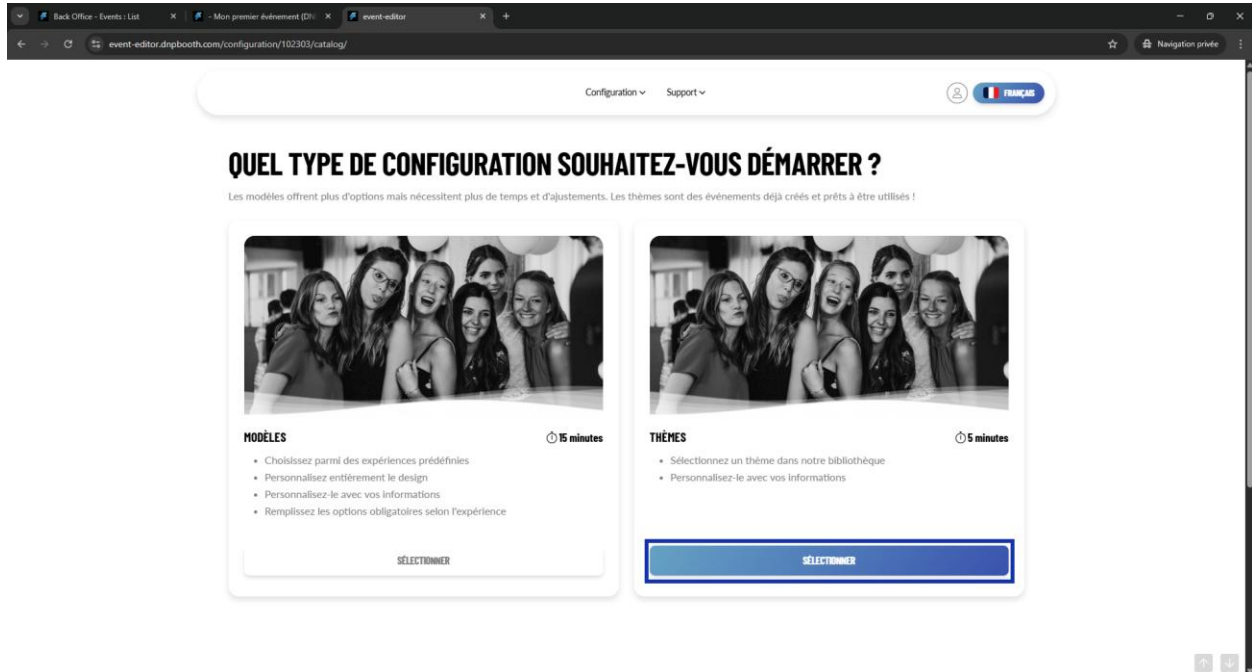

Click the “+” button next to the type of theme you want to set up, and then choose a theme.

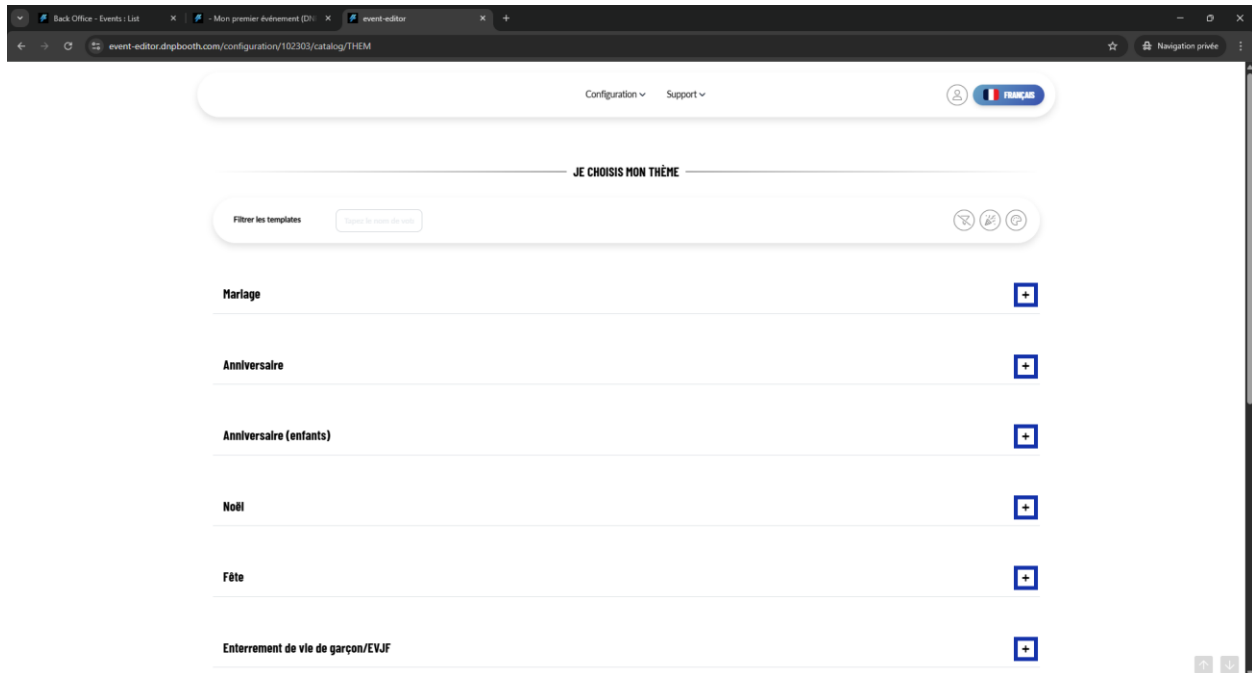

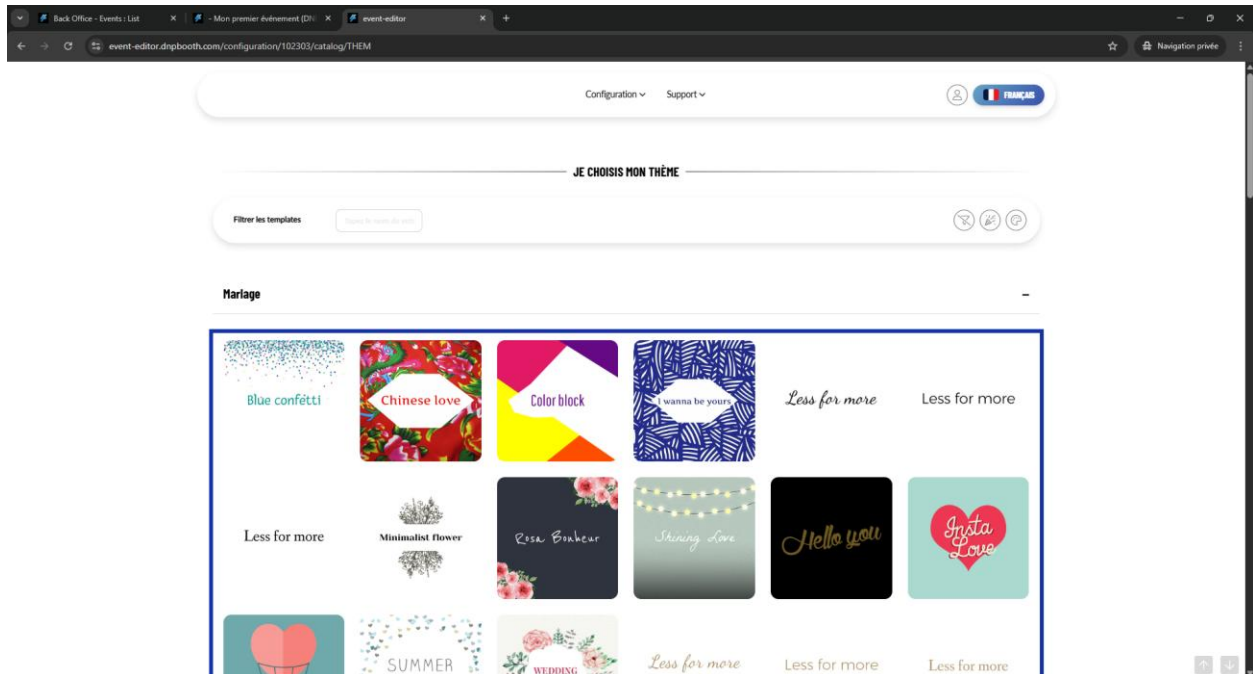

Once you've chosen your theme, you'll move on to setting up your event, which is organized into two main tabs:

- The editing of the elements of your event
- The editing of the textual parameters of your event

In the first tab, there are several sub-tabs:

- General: concerns the main elements of your event (here the names of the bride and groom)
- Layout: lets you choose which photo frames from your theme will be displayed at your event.
- Impression: to set up automatic or manual printing and to limit the number of times the same photo can be printed.
- Languages: concerns the language of the texts displayed in your event.

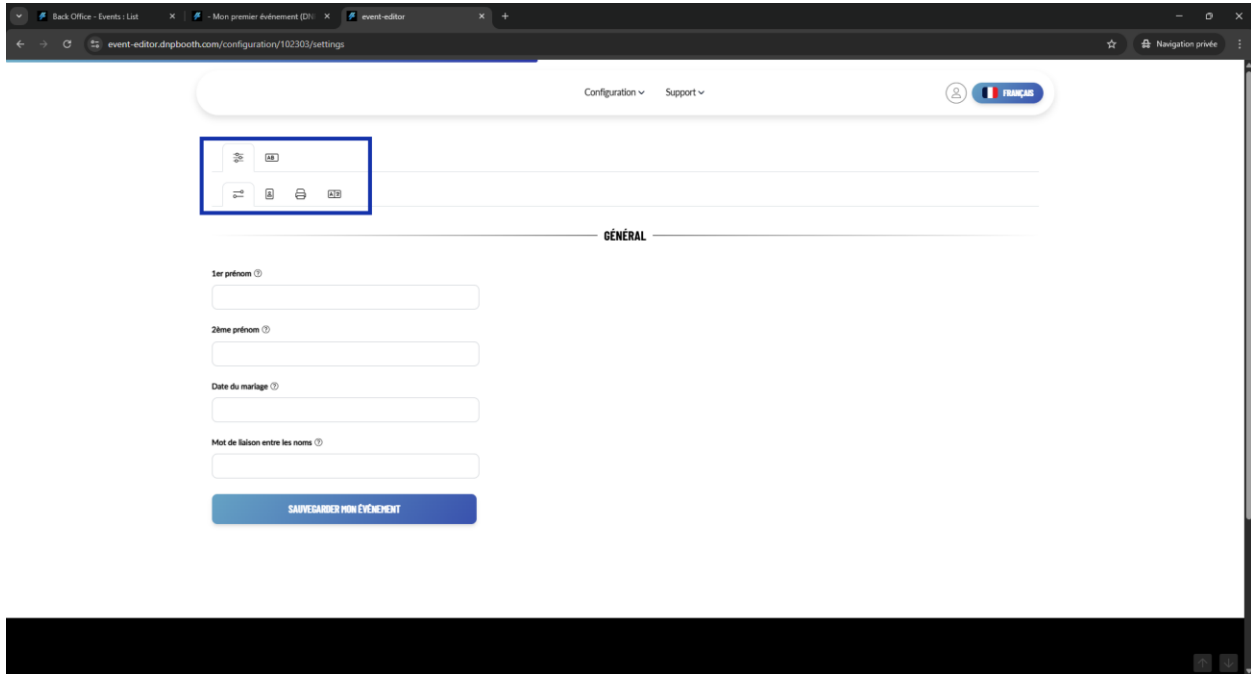

4. Fill in the general information in the "General" menu.

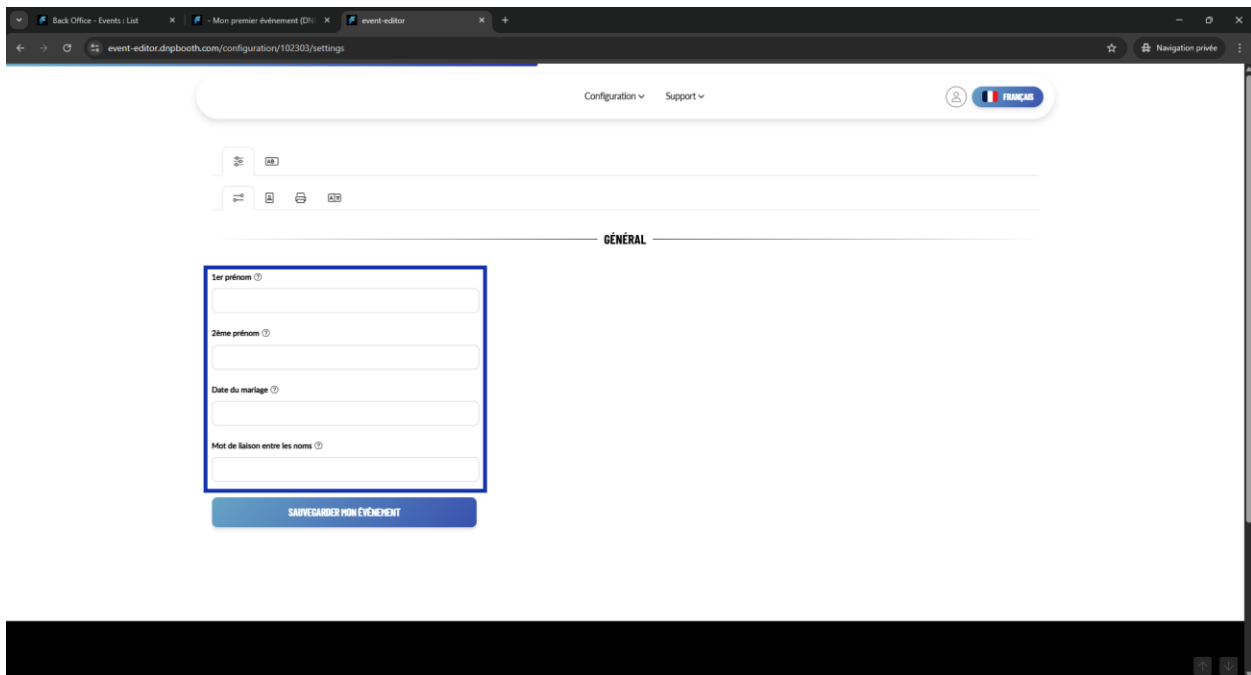

5. Choose your photo frames from the "Layout" menu, then click on "Add." You can add up to 15 photo frames in a single event.

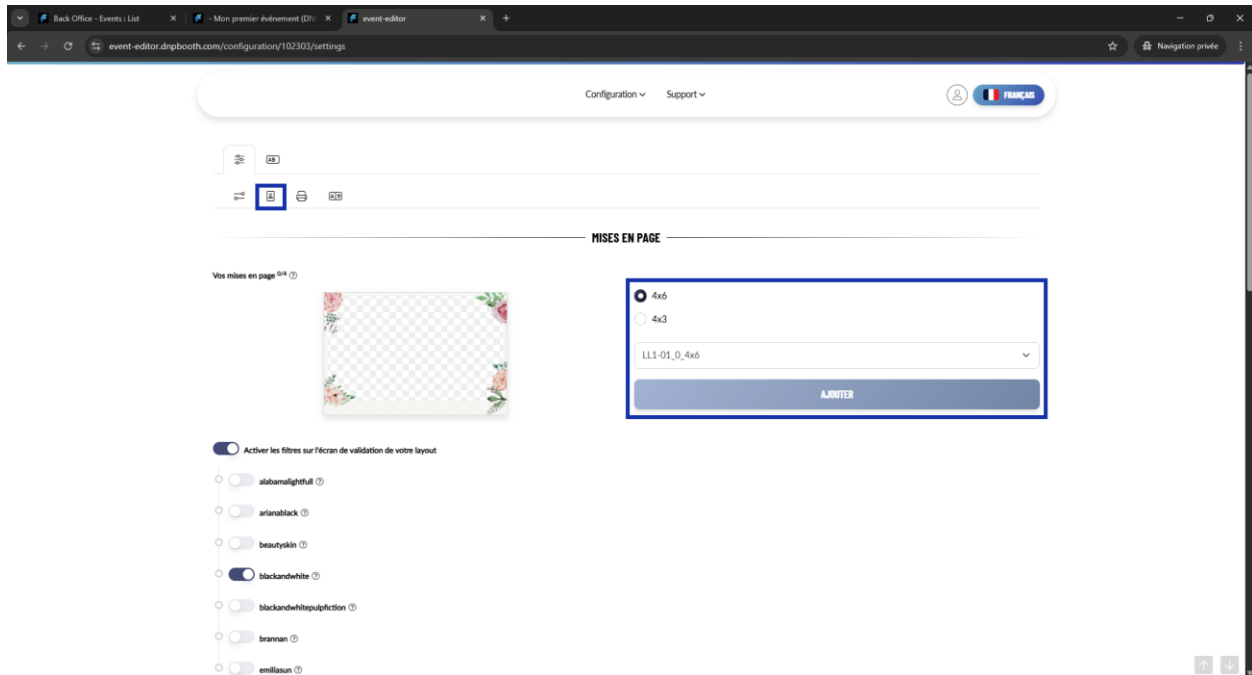

For each added frame, a summary table appears with options, along with a download area that features a dedicated action button on the right side. This button lets you edit your frame by adding text and images, as well as adjusting the positions and sizes of the elements you added earlier.

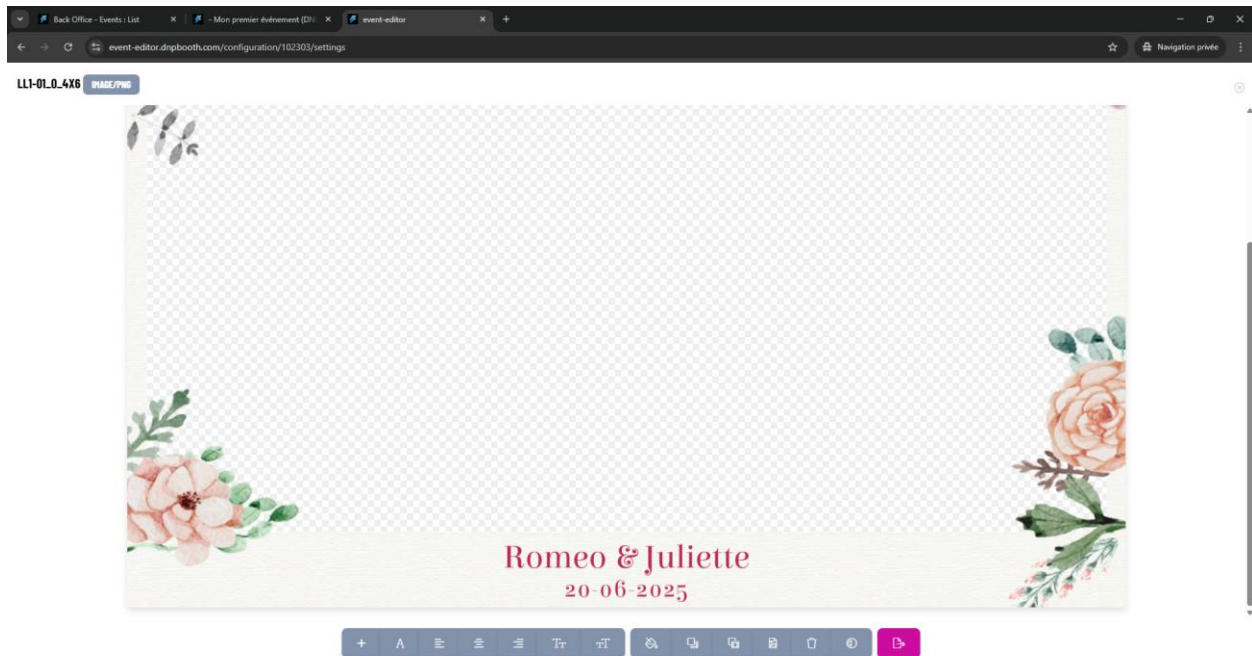
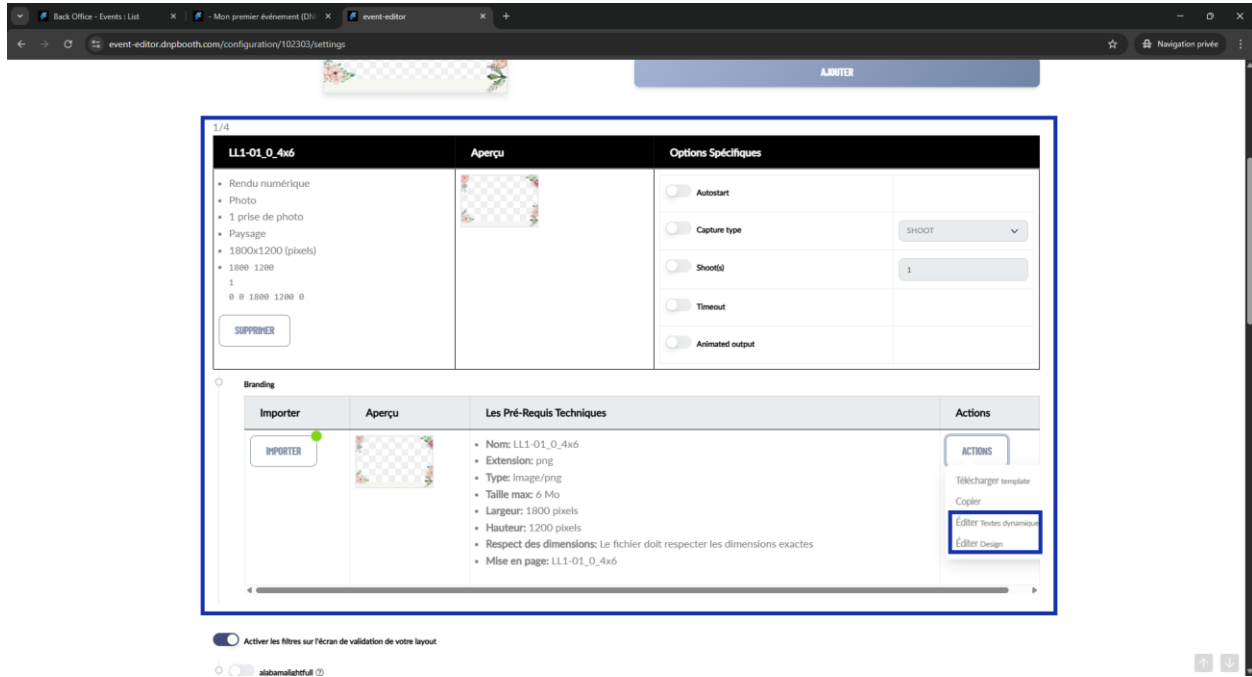

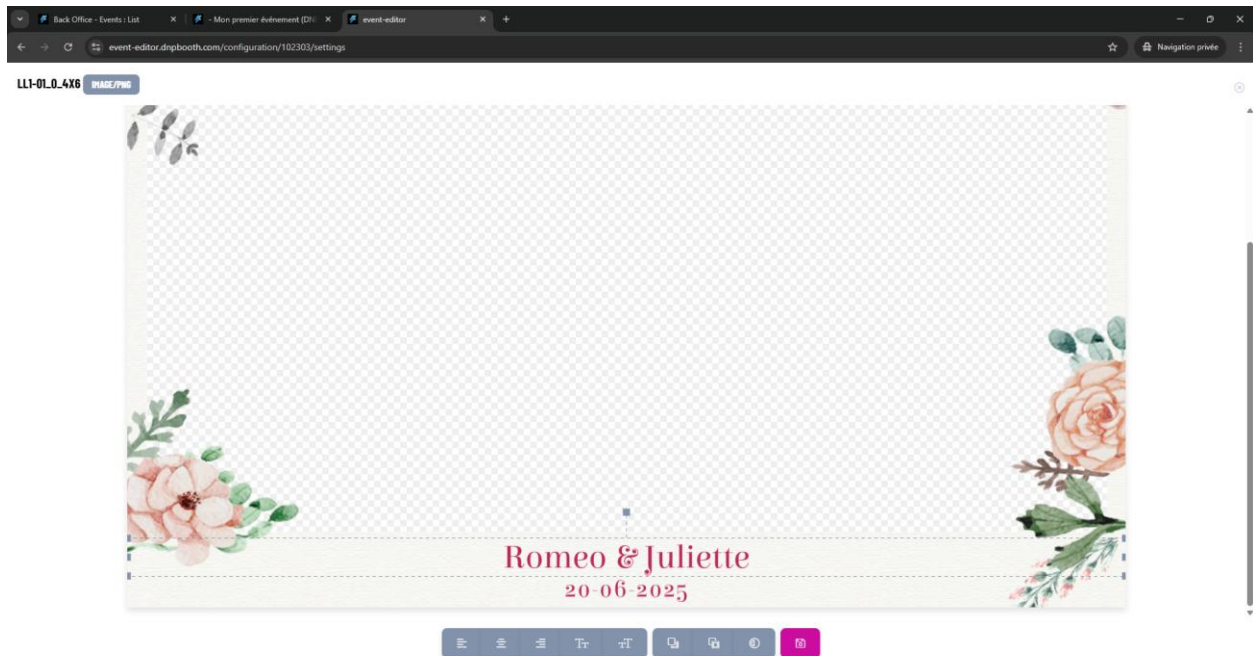

At the bottom of this tab, you can choose the filters that will be available for users to select during your event. We recommend using a maximum of 5 filters at the same time.

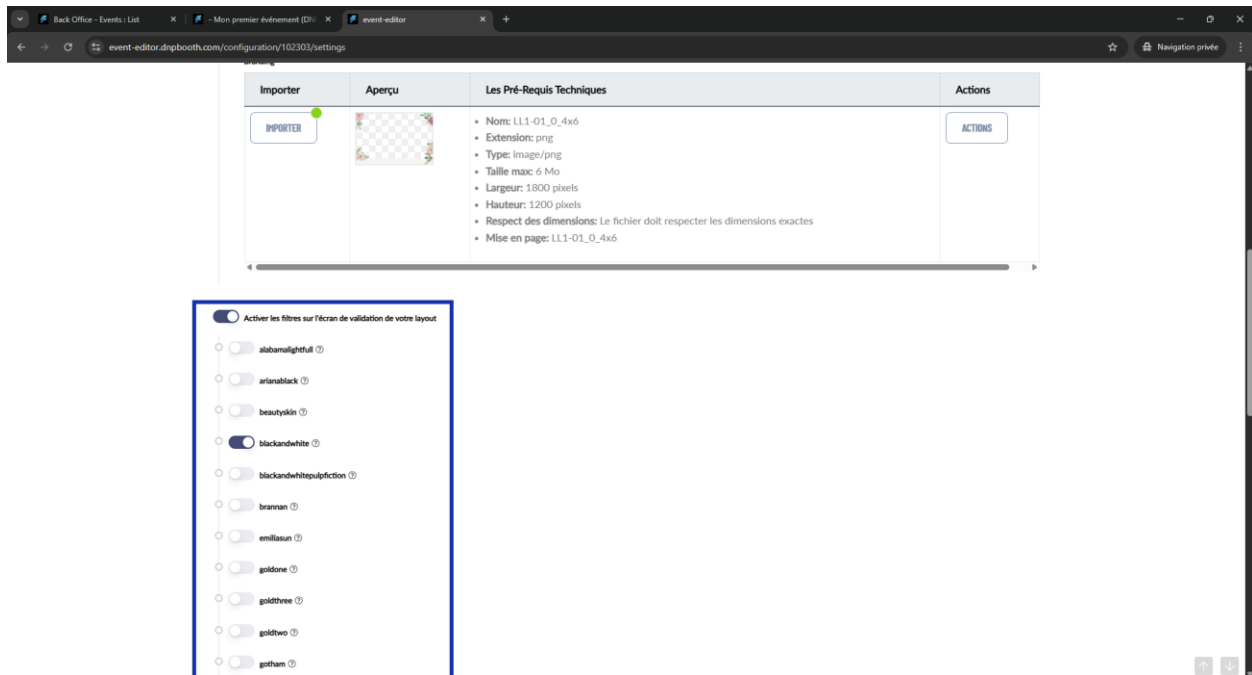

By default, the printing option is up to the user, but you can change it in the "Print" menu. You can also increase the maximum number of prints available for your event.

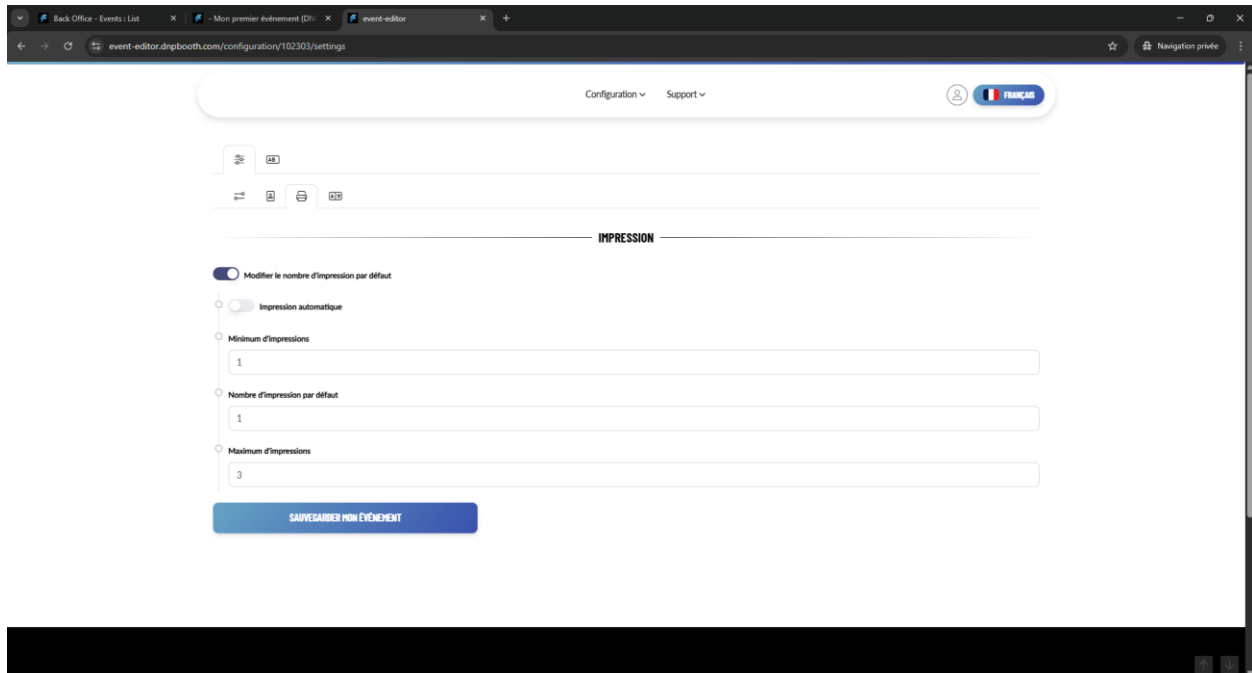

Finally, you can choose the default language for your event and offer up to three additional languages.

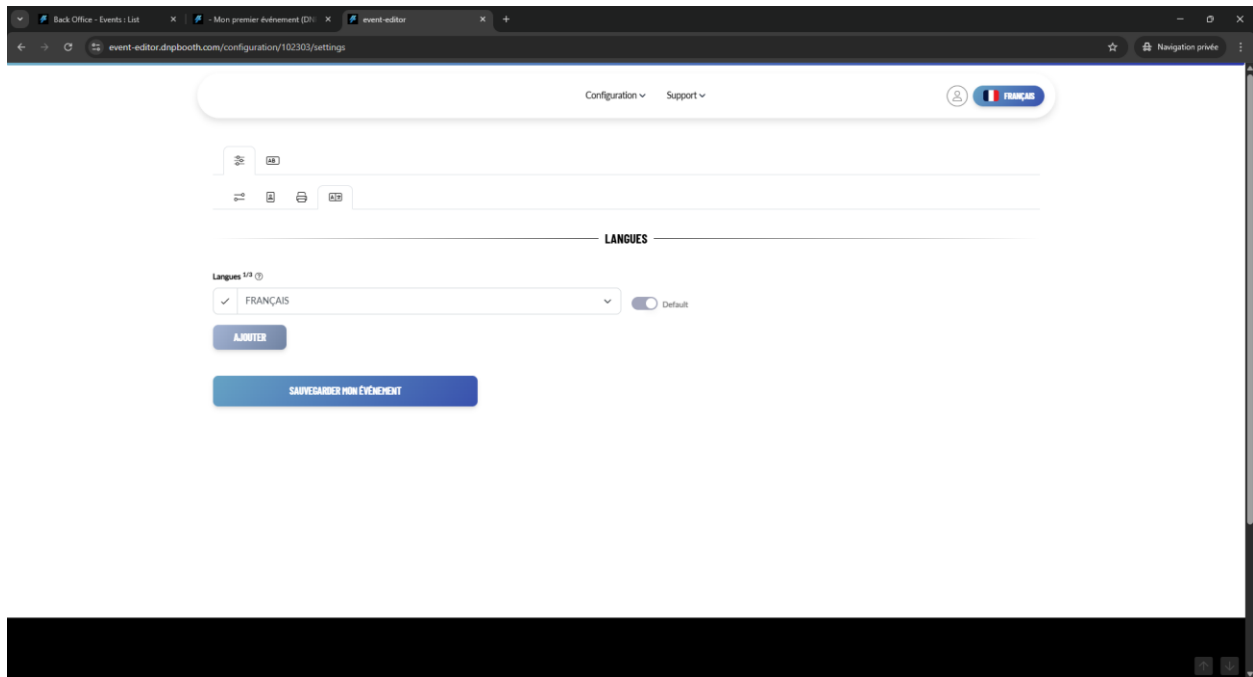

If you need to change any text, you can do so in the Text Settings tab.

IMPORTANT: Please note that if you change the language after modifying your settings. Textual, all your changes will be lost!

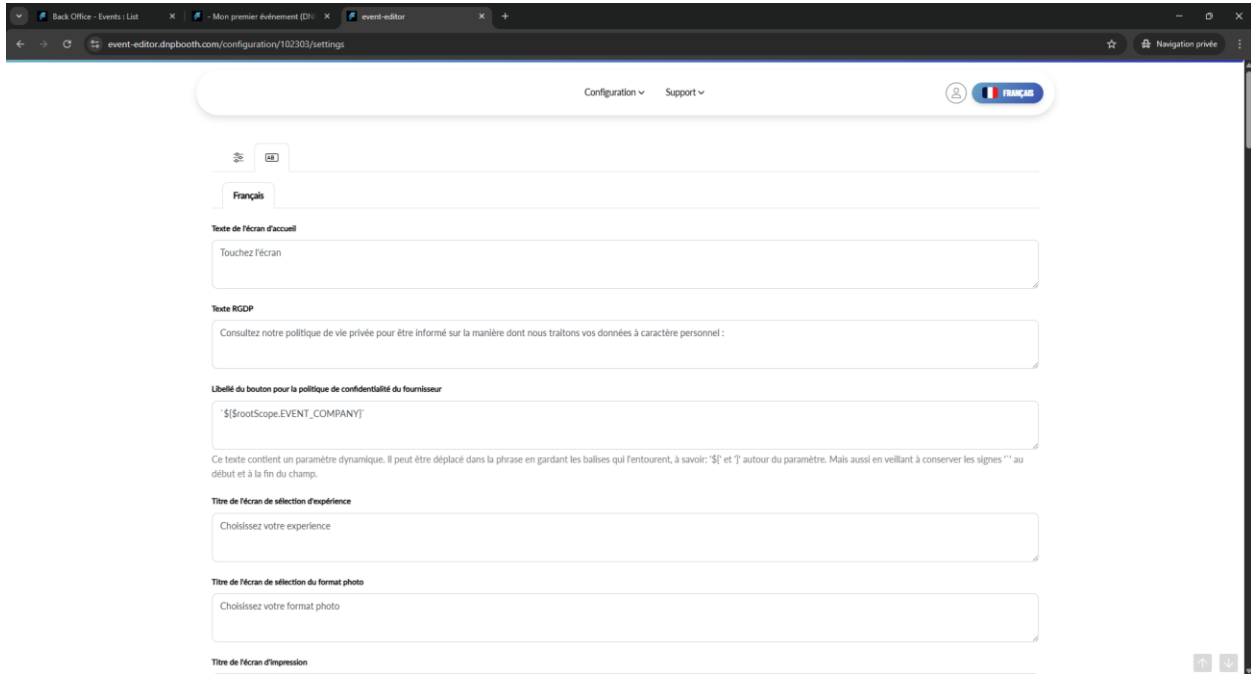

10. Save your configuration once completed.

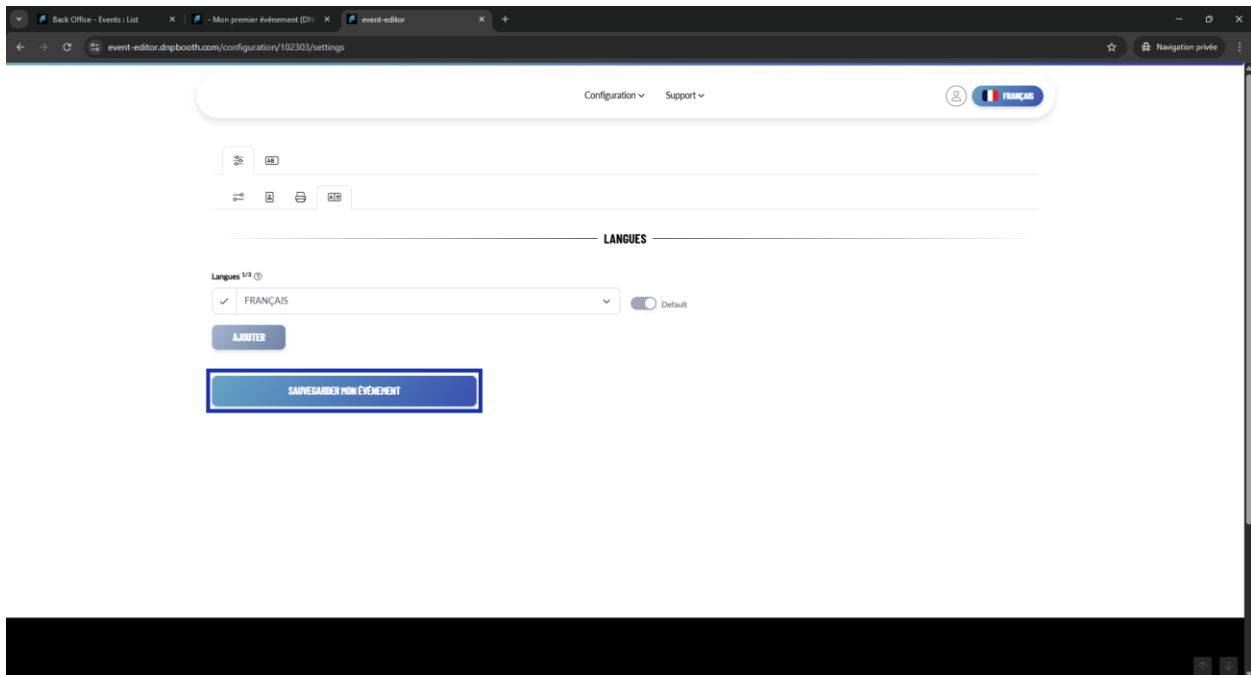

Once you've saved your configuration, you'll be able to change the settings for sending the photo to the user.

Please note: To send the photo via email, you need to have a PRO license, which means you must have purchased a PRO DATA package beforehand.

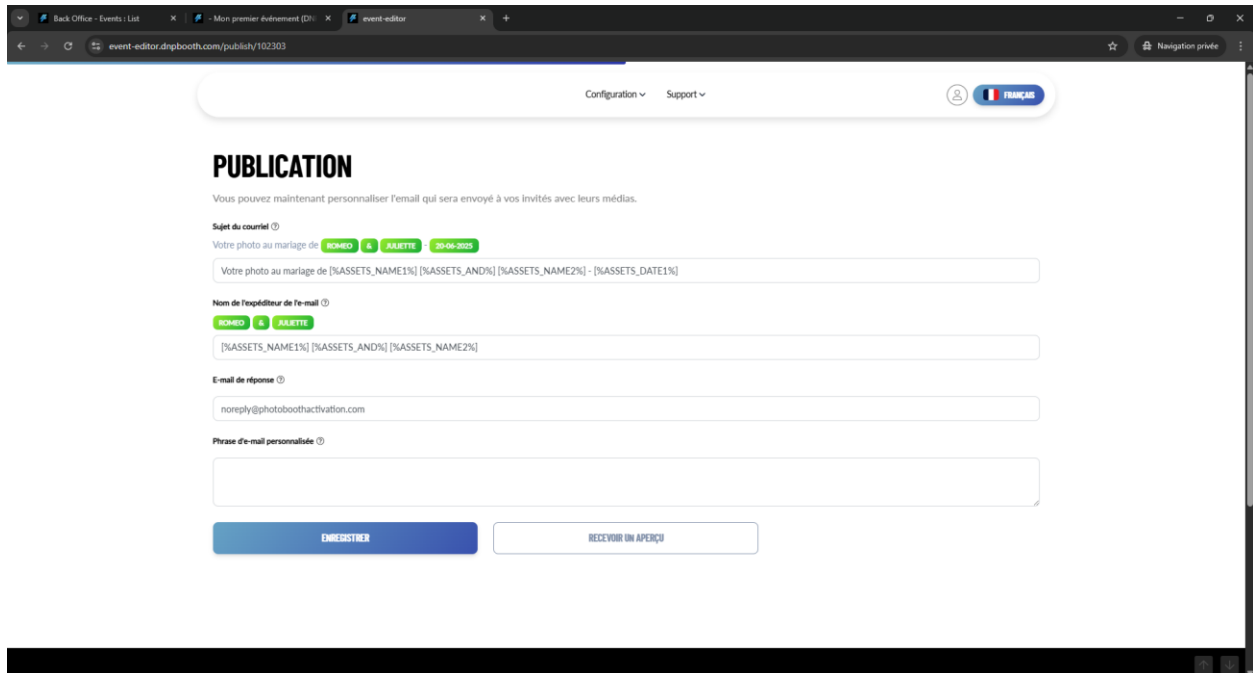

By default, we add the tags you provided in your information. general.

To help you understand:

[%ASSET_NAME1%] = First name you entered (wedding, birthday, baby shower)

[%ASSET_NAME2%] = The second name you entered (for marriage only)

[%ASSET_AND%] = The connecting text between the two names (for marriage only)

[%ASSETS_PARTY%] = Message for your group (for group events only)

[%ASSETS_BIRTHDAY1%] = Includes the age and unit you provided (for date of birth only)

Feel free to remove this information and replace it with whatever you or your client prefers.

Click the "Save" button at the bottom of the page to complete your event setup. You will be redirected to the summary tab, where you'll find your event ID, ready to be downloaded to your kiosk.

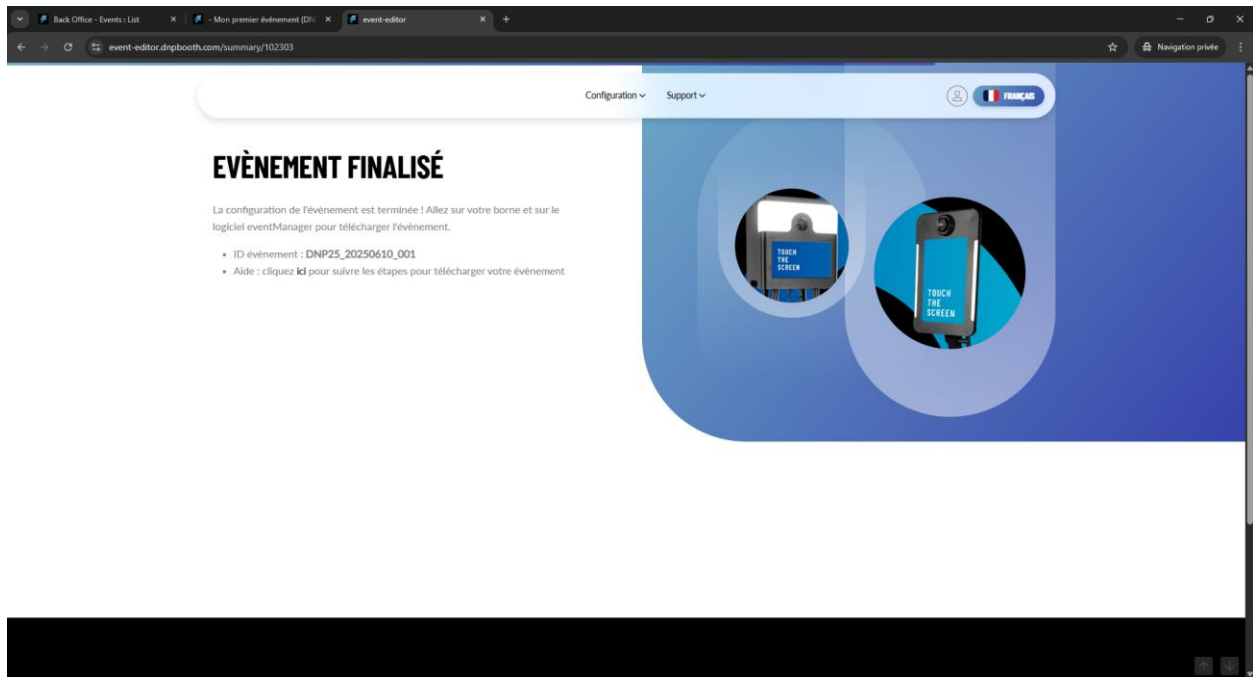

STEP 5: DOWNLOAD AND LAUNCH THE EVENT ON THE PHOTOBOTH

To download and start the event created on the photo booth, go to the booth and double-click on the "Event Manager by Sharingbox" software to launch it if it isn't already running.

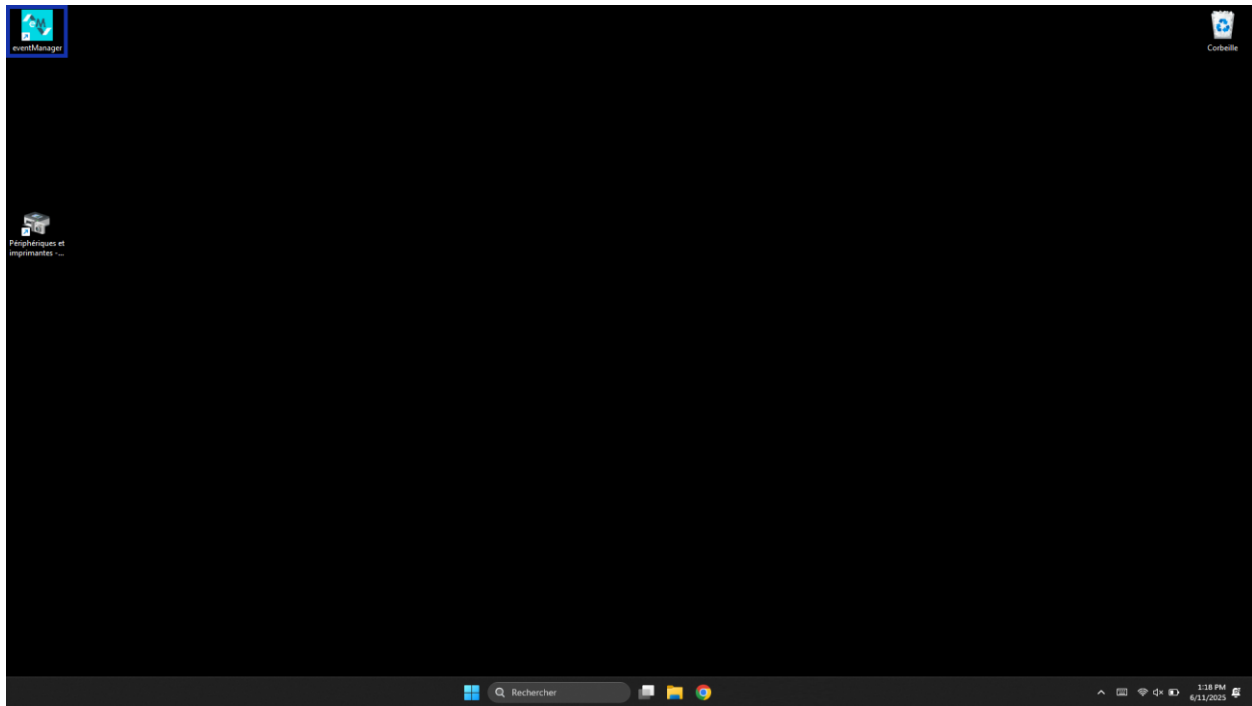

2. Type your access code that was provided to you in the welcome email received earlier.



3. Click the "New" button, select your event ID from the dropdown menus, and then click the "Download" button.



4. Once the download is complete, the event will show up in the list, ready to be started. Just press the "play" button to begin.

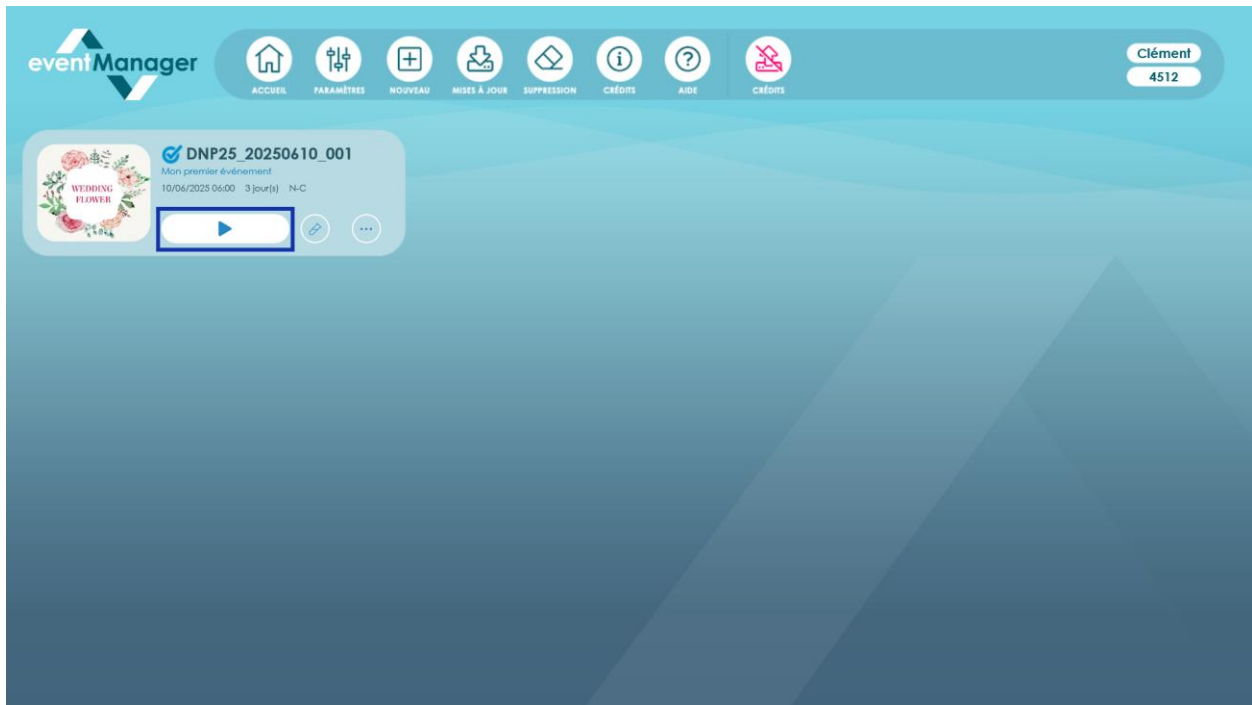

STEP 6: RECOVER THE MEDIA FROM YOUR EVENT

Once your event is over, you'll be able to collect all the media captured during it and save them in a folder, either on your device or on a USB drive connected to it.

Double-tap at the top right of the screen to land on the main screen of the eventManager.



2. Type your access code that was provided to you in the welcome email received earlier.

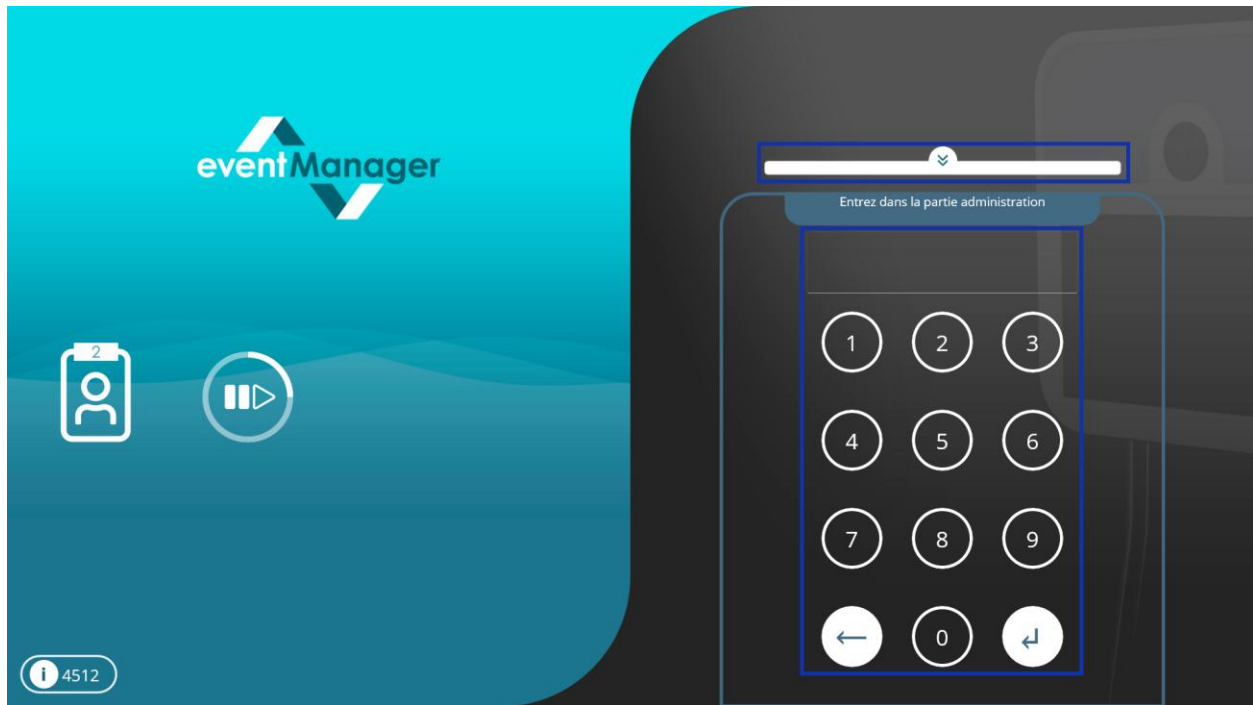

3. On your event, click the button that looks like “...” and then select “Export Media” in the pop-up window.



4. Confirm the information window, and then a Windows dialog will appear, allowing you to choose where you want to save all the media captured during your event.

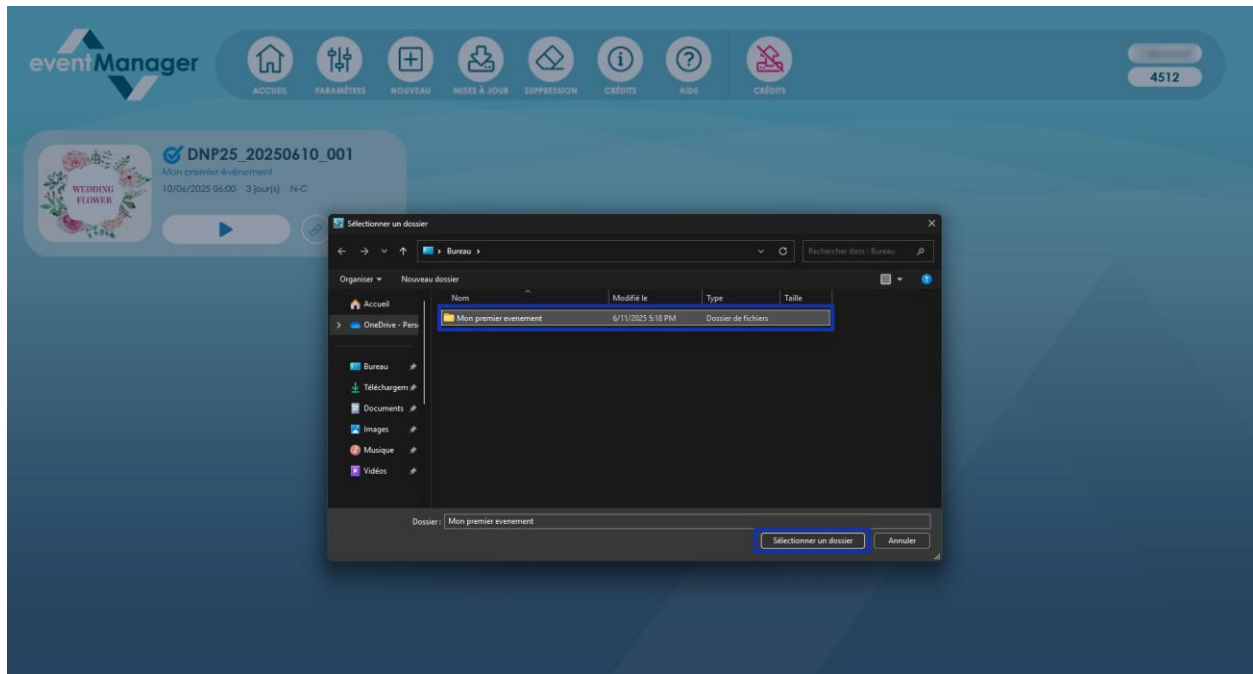
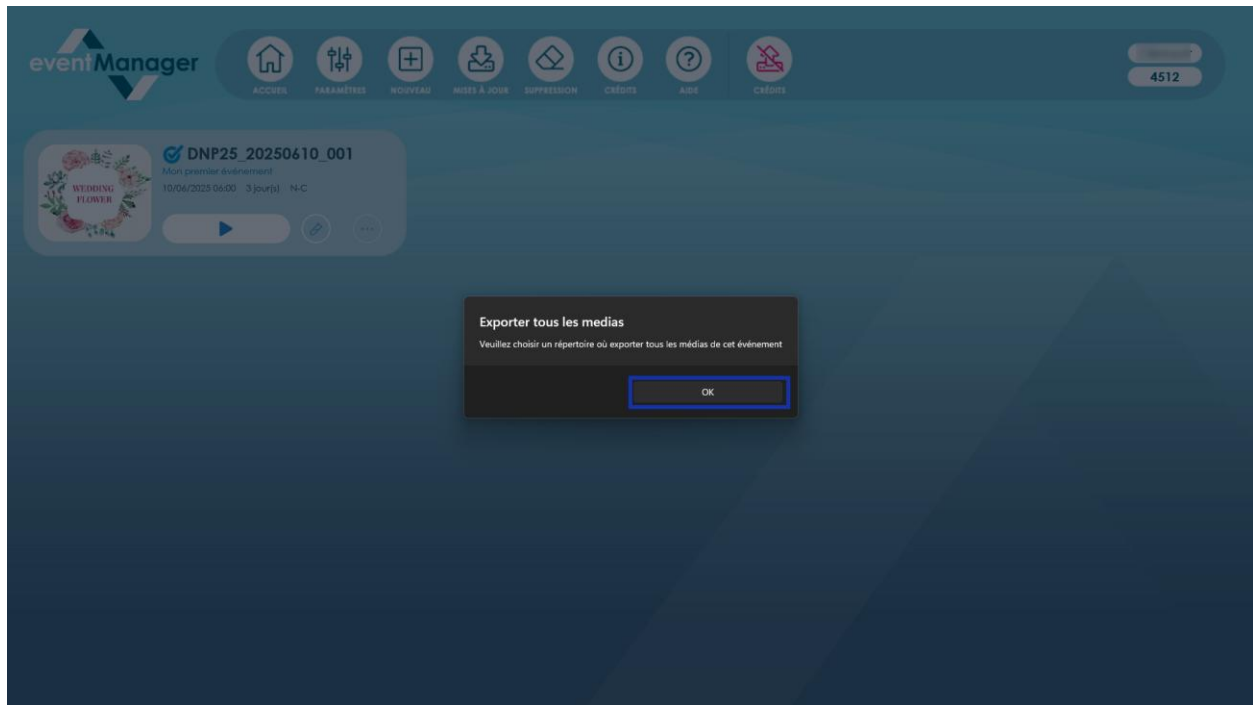

5. You will be notified when the export is complete.

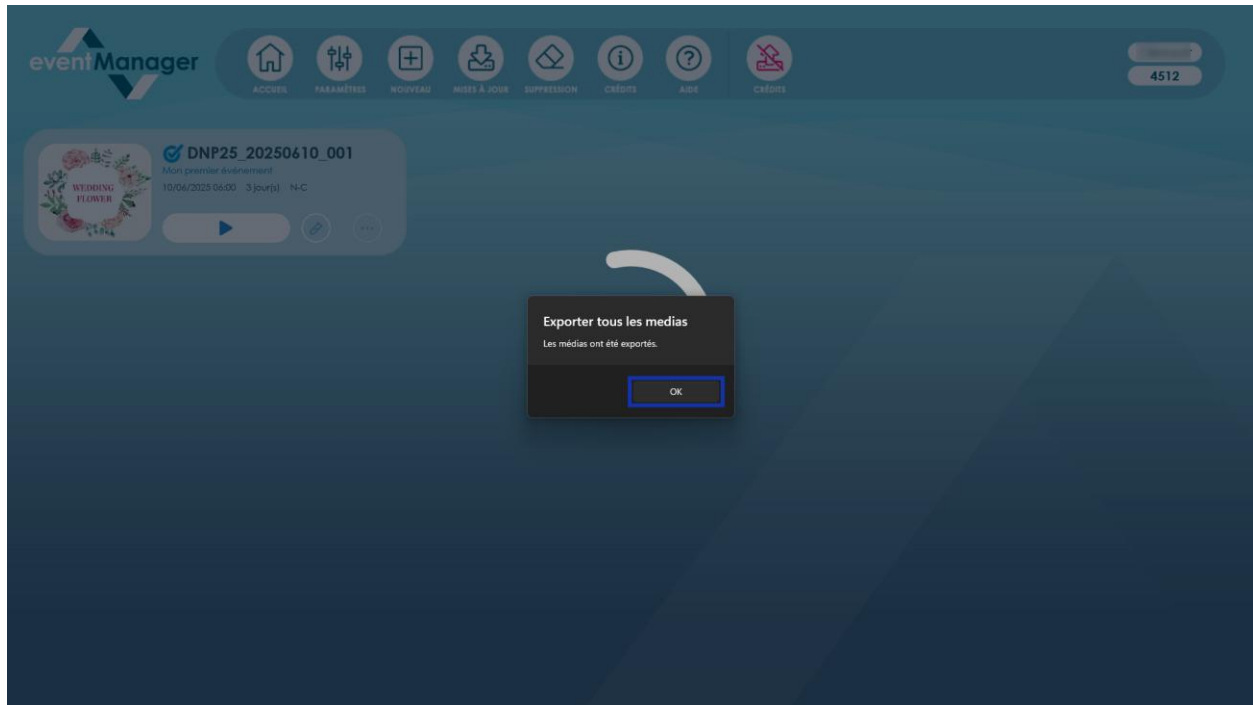

Note: If you have a PRO DATA package assigned to your photobooth and it is connected to the internet, all media will be published and accessible from your event space.

