



DS-K50

Point-of-sale
photo printing system

- ▶ ELEGANT COMPACT DESIGN
- ▶ VERSATILE AND FLEXIBLE
- ▶ COMPLETE QUALITY PHOTO SERVICE
- ▶ GREAT PRODUCT DIVERSITY
- ▶ CUSTOMISABLE
- ▶ EASY TO OPERATE
- ▶ SMALL SIZE

DT-T9 LITE 1-YEAR GUARANTEE
DS620/DS820 2-YEAR GUARANTEE

Versatile concept for instant photo printing

The **DS-K50** is a complete solution comprising the **DT-T9 Lite** photo terminal and an elegant rack specially designed to house DNP printers, and to fit in with the style of your store.

The **DT-T9 Lite** terminal comes with the **SnapLab Pro** photo software, a simple, intuitive interface allowing you to offer your customers a wide range of quality photo products. The simple, efficient print management guarantees a smooth and agreeable user experience.

With the DS-K50, boost your **productivity** and make the most of the great **flexibility** offered by our broad range of print formats and types.



DS-K50

A wide range of products

Numerous photo formats and products

- ▶ Multi-format photo prints
- ▶ Panoramic prints
- ▶ Retro prints
- ▶ Frames
- ▶ Mix'n'Match
- ▶ Greeting cards
- ▶ Calendars
- ▶ Photo albums
- ▶ Photo cards*

Biometric identity photos (option)

- ▶ Analysis, verification and validation of compliance for identity photos with the official requirements of each country.
- ▶ Save identity photos to USB sticks.



*Requires a Fargo HDP5000 card printer.

Modular and customisable

The DS-K50 is specially designed to house **up to three DNP DS620 printers** thus offering maximum flexibility to meet your needs. One of the **DS620 printers** can be replaced by a DS820 printer to offer your customers larger print formats.

Customise the rack **to your brand requirements** by affixing stickers or magnetic Point-of-Sale Advertising. The software can also be customised.

Optimised for easy operation and maintenance

The rack is **secured** with a square key, and has a magnetic latch on the front. Each printer is placed on rails inside the unit, ensuring easy access for loading media and cleaning.

Fitted with four casters, the rack **can be moved easily and oriented**, thus simplifying the servicing and maintenance operations.

Made of metal, **with an elegant design**, the rack provides optimum, robust protection for the printers while guaranteeing efficient operation in every type of working environment whatever the circumstances.

SnapLab Pro full: an optimised software program

For the customer

- ▶ Easy to use
- ▶ Intuitive photo processing: choice of frames and filters
- ▶ Wire, WiFi and bluetooth connectivity
- ▶ Print monitoring

For the operator

- ▶ Ready-to-use solution
- ▶ Print monitoring
- ▶ Management of product categories
- ▶ Customisable interface
- ▶ Web statistics

Photo & Creation associated with SnapLab Pro allows you to enhance the offering for your customers: discover our collection of creation products (bamboo photo blocks, customised magnets, photo albums) which will increase their satisfaction and your revenue.

Guarantee and technical assistance

- ▶ One-year guarantee as from the DNP PIE invoicing date**.
- ▶ Need assistance? Contact your distributor or the DNP Photo Imaging team of experts directly:

- ▶ **By phone:** +33 (0) 149 384711
Monday to Saturday from 9am to 1pm and 2 to 5pm
- ▶ **by scanning this QR code**
- ▶ **or on** <https://www.dnpphoto.eu/en/technical-support/contact>



** Under the general DNP DS-K50 guarantee conditions: 1-year guarantee for the DT-T9 Lite and 2-year guarantee for the DS620 and DS820



Technical characteristics

All these specifications are subject to change without notice

Compatible printers	DS620, DS820
Print formats	From 5x15 cm (2x6") to 20x30cm (8x12")
DT-T9 Lite terminal	
Screen	23" PCAP touchscreen
Weight	20 kg
System performance	CPU: Intel® core i3-10100 Memory: 8 GB, DDR4 Storage: SSD M2 250 GB OS: Windows 10/11 IOT 2021 LTSC, 64 bit
Mobile connectivity	Wired connection for smartphone: Micro USB, USB type C, Lightning Wireless link: Direct WiFi or Bluetooth (dongles supplied)
Media reader	SD, Micro SD, MS, MS micro, xD, CF, USB stick
USB ports	Front (under the metal plate): USB 2.0 x 7 ports, 3 of them dedicated to operation of the terminal Rear: USB 2.0 x 5 ports, 1 x LAN
Electricity consumption	230 V, 50 Hz, 400 W
Options	1D/2D bar code reader, receipt printer
DNP photo software	SnapLab ProW

Technical drawing

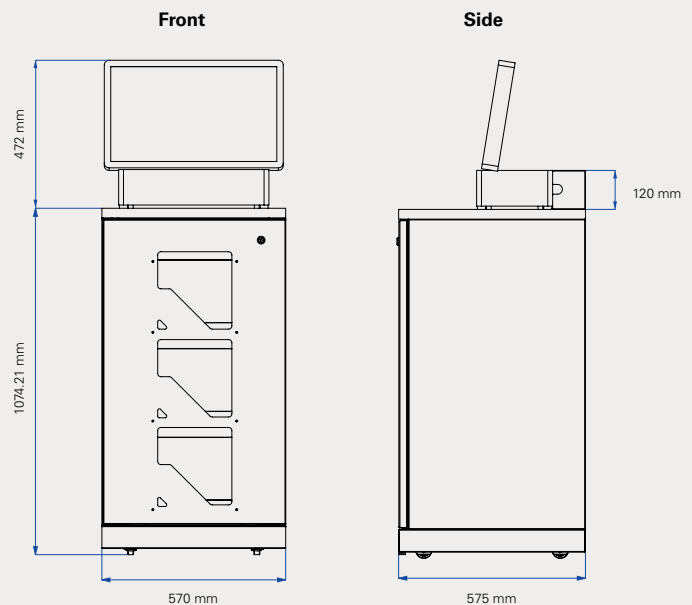

DNP PHOTO IMAGING EUROPE
22, Avenue des Nations
95948 ROISSY C.D.G. Cedex
FRANCE
Tel: +33 (0) 149 386550
www.dnpphoto.eu